

DF-2/DF-2+

MEDIUM VOLTAGE SWITCHGEAR



DF-2, a modular concept combining all medium voltage functions. Now also available IAC AFLR 25 kA/1s.

DF-2'S MODULAR DESIGN ALLOWS YOU TO CREATE RATIONAL, ECONOMICAL & CUSTOM-MADE COMBINATIONS OF MEDIUM VOLTAGE CUBICLES (WITH A RATED VOLTAGE OF 12, 17,5 OR 24 kV).

SGC

SwitchGear Company

THE SPECIALIST IN MEDIUM VOLTAGE SWITCHGEAR

www.switchgearcompany.eu - info@switchgearcompany.eu

TABLE OF CONTENTS

1. OVERVIEW	p. 4
1.1. DF-2 DESIGN PHILOSOPHY AND APPLICATIONS.....	p. 4
1.2. MODULAR TYPE DF-2.....	p. 4
1.3. APPLICATION.....	p. 6
1.4. SF ₆ INSULATION.....	p. 8
1.5. STANDARDS.....	p. 8
1.6. INTERNAL ARC RESISTANCE.....	p. 9
1.7. DF-2+ OPTION WITH BUILT-IN ARC-KILLER SV-25.....	p. 10
2. COMPARTMENTS	p. 11
2.1. SWITCHGEAR COMPARTMENT.....	p. 11
2.2. BUSBAR COMPARTMENT.....	p. 11
2.3. CABLE COMPARTMENT.....	p. 11
2.4. LOW-VOLTAGE COMPARTMENT.....	p. 11
3. DF-2 MODULES RANGE	p. 12
3.1. TECHNICAL SPECIFICATIONS.....	p. 12
3.2. EXTENSIVE SPECIFICATIONS.....	p. 13
3.3. MODULES - SPECIFICATIONS & DIMENSIONS.....	p. 14
• DF-A.....	p. 18
• DF-A+.....	p. 19
• DF-P.....	p. 20
• DF-AV2.....	p. 21
• DF-AV3.....	p. 22
• DF-D.....	p. 23
• DF-D/EDN.....	p. 24
• DF-D+.....	p. 25
• DF-D+/EDN.....	p. 26
• DF-D-500.....	p. 27
• DF-DT.....	p. 28
• DF-DT + vt.....	p. 29
• DF-AAD.....	p. 30
• DF-AAD ESW.....	p. 31
• DF-AAD+.....	p. 32
• DF-AAD+ ESW.....	p. 33
• DF-AAD / EDN.....	p. 34
• DF-AAD+ / EDN.....	p. 35
• DF-AAD/EDN + ESW.....	p. 36
• DF-AAD+/EDN + ESW.....	p. 37
• DF-AADT.....	p. 38
• DF-AADT + vt.....	p. 39
• DF-LK.....	p. 40
• DF-LKK.....	p. 41
• DF-LKE.....	p. 42
• DF-LKKE.....	p. 43
• DF-T.....	p. 44
• DF-C-750.....	p. 46

- DF-C-500 p. 50
- DF-LKB p. 52
- DF-DKB p. 53
- DF-K p. 54
- DF-K +ESW p. 55
- DF-K+ +ESW p. 56

4. INSTALLATION GUIDELINES

4.1. TECHNICAL ROOM HEIGHT	p. 57
4.2. ACCESS DOOR DIMENSIONS	p. 57
4.3. MINIMUM FREE PASSAGE FOR THE CUBICLES	p. 57
4.4. EXAMPLE LAY-OUT OF MV ROOM	p. 58
4.5. TECHNICAL ROOM VENTILATION	p. 59
4.6. POSITIONING IN TECHNICAL ROOMS OF LEVEL -1	p. 59
4.7. GENERAL REMARKS	p. 59

5. PRODUCTION PROCESS

5.1. PRODUCTION PROCESS OF THE DF-2 CUBICLES IN LANDEGEM	p. 60
--	-------

6. OTHER PRODUCTS BY SGC - SWITCHGEAR COMPANY

	p. 62
--	-------

1. OVERVIEW

1.1. DF-2 DESIGN PHILOSOPHY AND APPLICATIONS

SGC - SwitchGear Company is a fast-growing Belgian company that invests considerable time and energy in Research & Development to serve customers even better.



User-friendliness, safety and care for the environment were the main drive for developing SGC - SwitchGear Company's switchgear.

Over time SGC - SwitchGear Company has developed the "DF-2", a modular concept which combines all medium voltage functions. It allows SGC - SwitchGear Company to provide "made-to-measure" solutions for all your medium voltage needs.

The DF-2 cubicles and associated switchgear offer a wide range of applications and can be used worldwide in many industries. DF-2 cubicles can be used with distribution and dispersion switchgear, electrical substations and medium voltage engines, wind generators, cogeneration, and much more.

The DF-2-concept provides a solution for all your needs and demands: it can replace obsolete installations and extend existing installations, and it is also perfectly suitable for entirely new constructions.

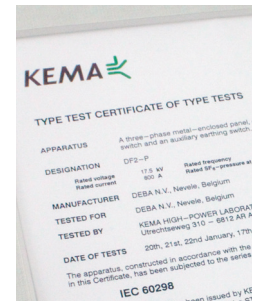

1.2. MODULAR TYPE DF-2

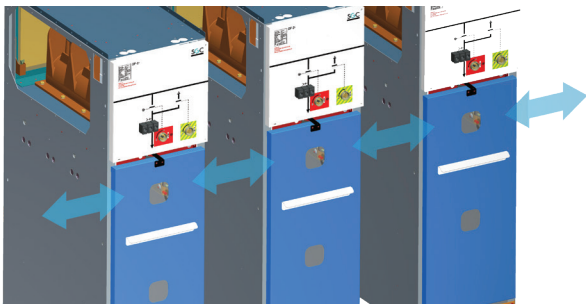

The DF-2 system is a modular concept based on the "building blocks" principle, which means that cubicles are produced in series. As a result, the modular DF-2 concept meets the highest technical standards in a rational, economically sound way. The combination of cubicles is unlimited. Very complex diagrams of distribution and transformer switchgear can be compiled through this extensive spectrum of possibilities.

The cubicle dimensions are very dense since the switching occurs in an SF₆ insulation medium. The semi-compact cubicles are particularly beneficial if the available

space should pose a problem or if economical factors play an important role.

Cubicles also contain all functional interlocks which allows for effortless application, according to all current standards, and which allows installation in consumer work spaces. As a result, capacity loss will be minimal. Additionally, the cubicles have been fitted with a system for pressure release which shields the user from the consequences of an internal arc.

"A modular concept combining all medium voltage functions..."



1.3. APPLICATION

Power stations generate electrical power, with voltages up to 1.000.000 V, which is transported to transformer stations and dispersion stations.

These substations distribute medium voltage (+/- 10.000 V to +/- 24.000 V). Here too, a number of SGC - SwitchGear Company's cubicles are used. A medium voltage grid starts from every substation and supplies a large area with medium voltage.

Wherever medium voltage enters residential areas, industrial production companies, market gardening, hotels, sport venues, and more, there is a medium voltage switchboard fulfilling four essential functions.

- POWER SUPPLY:** the utility providers feeder is branched off to allow switching.
- PROTECTION:** the installation is protected with a load break switch with HRC fuses, or by a circuit breaker with a safety relay.
- MEASUREMENT:** the energy consumption is measured on the high-voltage, or low-voltage side.
- TRANSFORMATION:** medium voltage is transformed into low-voltage (690 V-400 V-231 V).

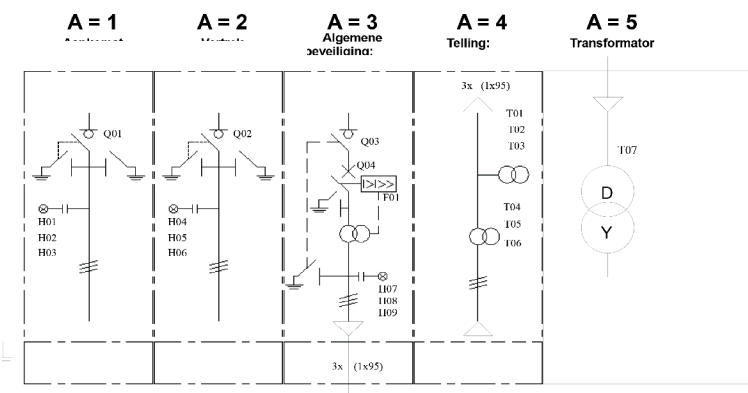
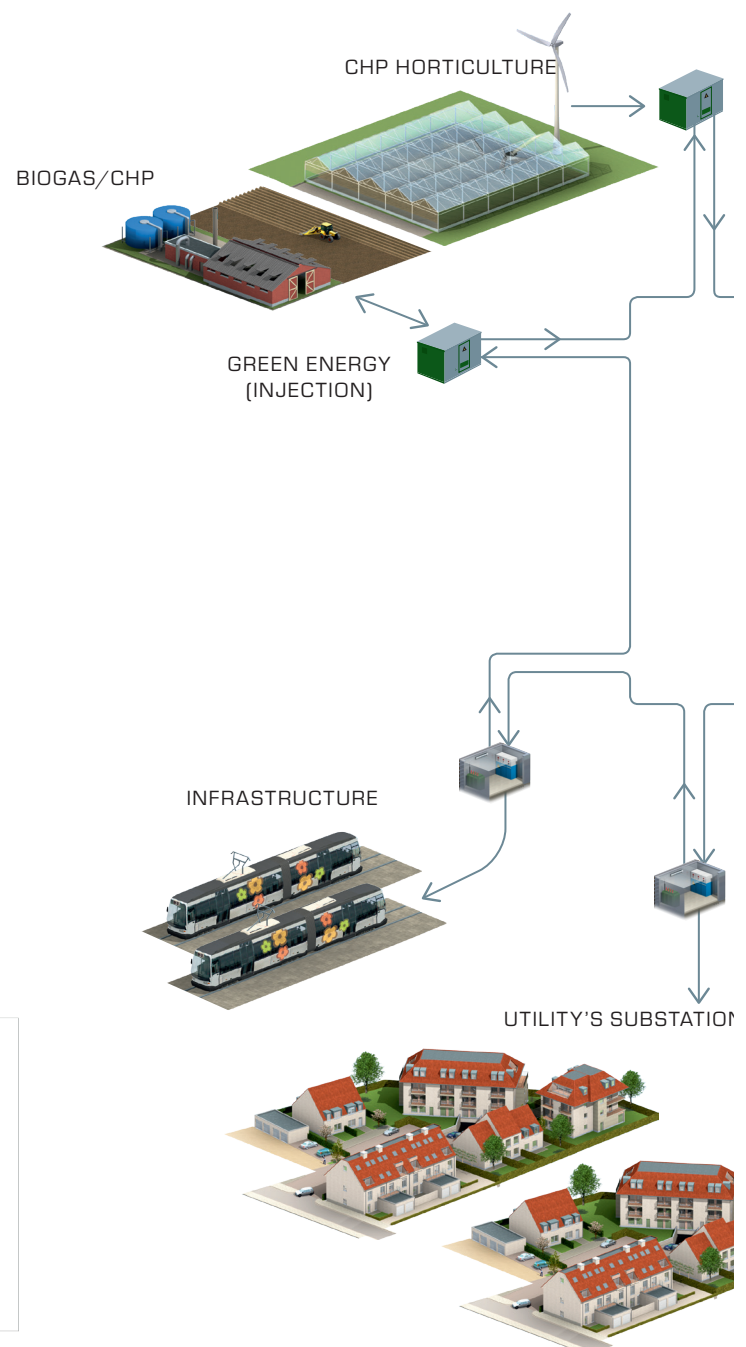
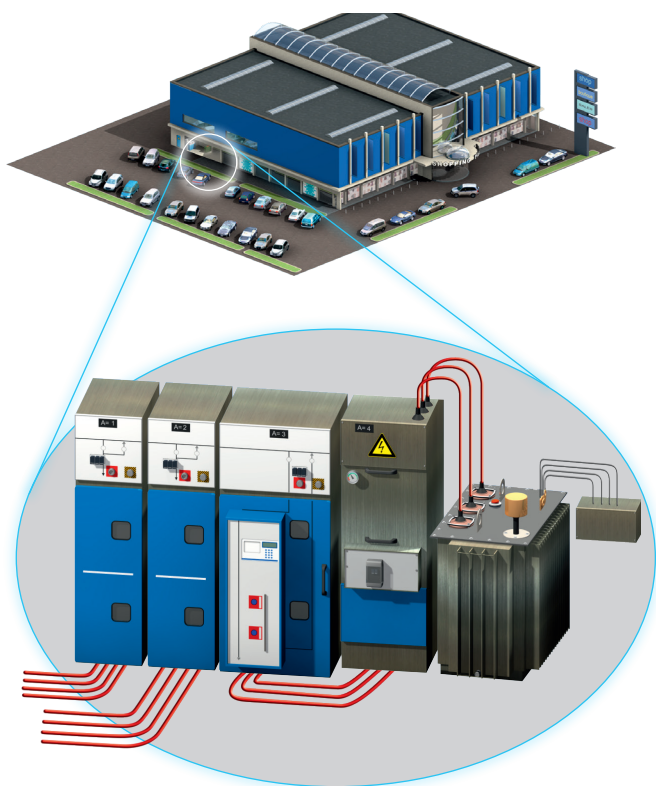

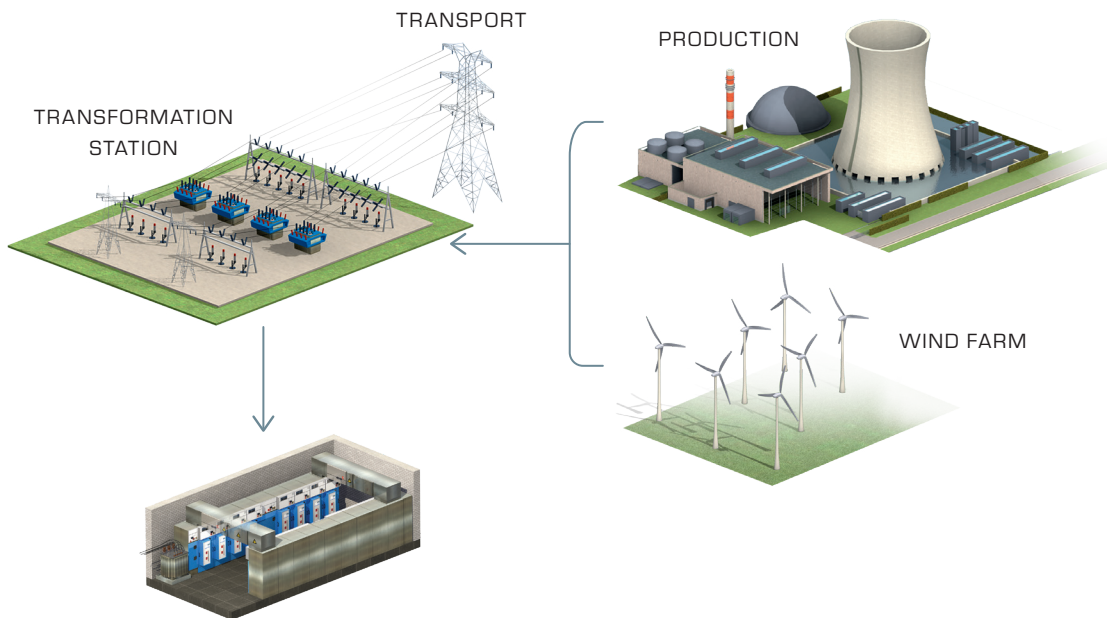

MEDIUM VOLTAGE SWITCHGEAR

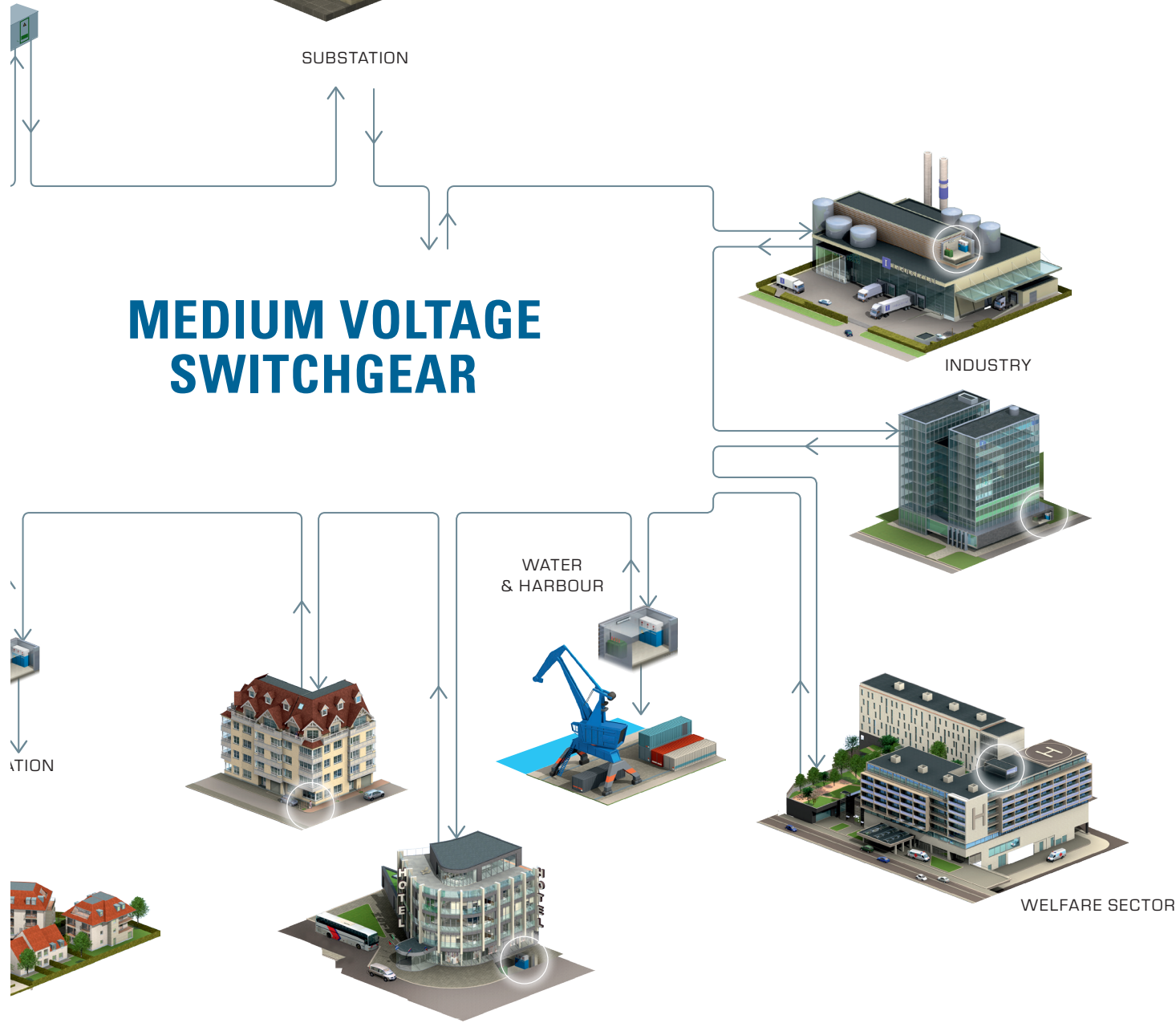

1.4. SF₆ INSULATION

SF₆ stands for sulphur hexafluoride, which is a clear and odourless, inert, non-toxic and nonflammable gas. It is extremely stable, especially due to the six covalent connections of the molecule. SF₆ has a molecular mass of 146.05, 5 times heavier than air, which makes it one of the heaviest gasses. It can be obtained in cylinders anywhere in the world and is used extensively in different sectors such as the petrochemical field, the nuclear sector, and in electron microscopy. SF₆ is even found in double glazing.

For over 30 years SF₆ gas has proven to be superior as an insulation and interruption medium in high (HV) and medium voltage (MV) installations. One of the physical characteristics of SF₆ is that the gas neutralises electrons. Its insulating property makes SF₆ especially important for medium and high-voltage switchgear, switches and transformers.

In MV and HV installations, it is extremely important that the cables and switchgear are well insulated to avoid electrical arcs or short-circuits. There is even an additional advantage: SF₆ gas acts as a space saver since it requires less space than air for switching purposes.

SGC - SwitchGear Company's RV44 load break switch is filled with SF₆ gas. Switches are "sealed for life" and require minimal maintenance. When it comes to recycling electrical components, current regulations require recuperation of components containing gas after their lifecycle ends. The recuperation of SF₆ products is regulated by law and executed by specialized companies according to a strict schedule. SGC - SwitchGear Company will be available at all times to help you with this specific problem.



SF₆ filling and sealing station

1.5. STANDARDS

The DF-2 system has been certified according to IEC (International Electrotechnical Commission) standards:

The whole concept conforms to ISO procedures, certificates and even with ISO 9001 guidelines. Cubicle testing is carried out in accordance with IEC regulation and self-enforced quality requirements.

"All cubicles are built according to IEC 62271-200"

SPECIAL OPTION : 1250 A

All cubicles can be supplied in a 1250 A design (according to IEC 62271-103 class E1), with a 1250 A busbar set



1.6. INTERNAL ARC RESISTANCE

A short-circuit or another malfunction can create an internal arc. An internal arc in a classic MV cubicle, could severely damage the installation and possibly injure the operator and electrocute him or her.

The DF-2 is designed to resist internal arcs, protecting both the operator and the installation. Through a strategic **pressure release system**, the internal arc is restricted to the compartment where it originated and it does not propagate towards the operator or to other compartments.

The anti-arc kit of DF-2 cubicles is specifically designed to minimize the consequences of an internal arc. By default all provided cubicles are fitted on the rear side with overpressure valves pointing downward.

The four valves are equally spaced among the total height of the cubicles: The upper valve is for the busbar and the three other valves protect both the cable compartment and the equipment compartment. The cubicle roof is fitted lengthwise over a depth of 100 mm.

Upon delivery, two reinforced side plates will be supplied in order to close the cabin completely, both to the left and right sides against the wall. As a result, an expansion space is created across the total height and width of the cabin.

For applications in accessible concrete outdoor cabins, the anti-arc kit allows gasses to be diverted to the base-ment area. There is an exhaust opening in the floor panel along the side of the wall specifically for this purpose.

DF-2 cubicles were **tested at Kema IAC (AFL)** for 20 kA/1s. at a rated voltage of 17.5 kV/24 kV according to IEC 62271-200, appendix A and met the 5 criteria. Now also available AFLR 25 kA/1s.

Consequently, all SGC - SwitchGear Company cubicles are internal arc resistant.

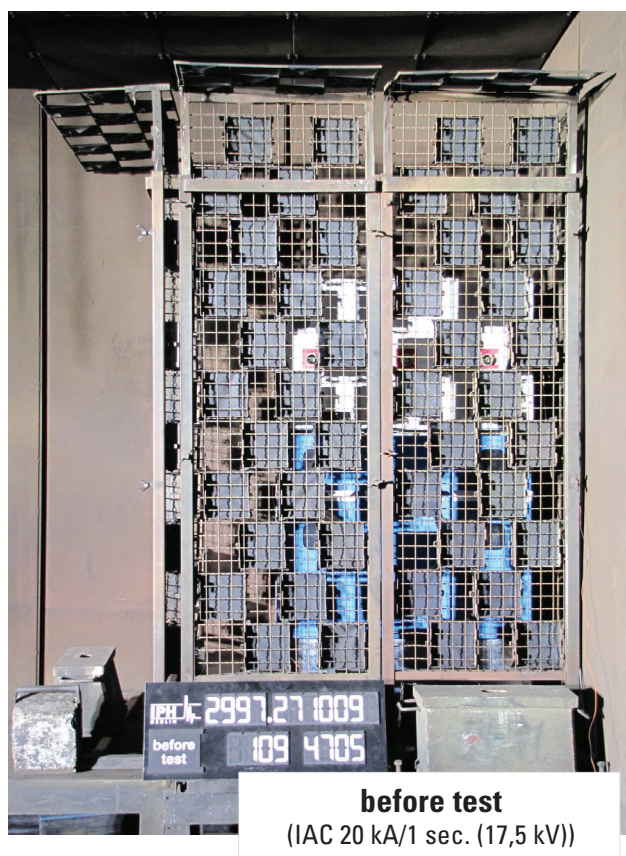

The various tests were always in accordance with IAC (AFL) for 20 kA/1s and IAC (AFLR) for 25 kA/1s. according to IEC 62271-200

1.7. DF-2+ OPTION WITH BUILT-IN ARC-KILLER SV-25 (only available up to 17,5 kV)

Protect your cubicles, your infrastructure, and especially your staff against the negative consequences of an internal arc. The built-in arc-killer extinguishes an arc in less than 50 ms.

The DF-2+ includes the arc-killer SV-25, a system for detecting and extinguishing an internal arc. The arc-killer extinguishes the arc by directing it to a metal earthed short circuit. The arc is extinguished in less than 50 ms.



KEMA type tested according to IAC: B, FLR 20 kA/1s. This solution is patented.



“The built-in arc-killer extinguishes an arc in less than 50 ms.”

A DF-2+ is a metal-enclosed cubicle of the DF-2 type combined with a shaft at the rear of the cubicle. The shaft absorbs the gasses (in case of an internal arc) that escape through the overpressure valves. **As a result, the expansion of hot gasses in a room can be reduced to an absolute minimum.** DF-2+ type cubicles offer protection against an internal arc classification IAC category B, FLR 20 kA 1 s. (F=frontal, L=lateral, R=rear)

As a result, the operator is protected against the negative consequences of an arc, whether they stand in front of the switchboard, next to it or behind it.



SGC - SwitchGear Company's patented SV-25 Arc-Killer takes **safety to a new level**. Not just the operator and the environment are shielded from harm, but the super-swift arc extinguishing system allows cubicles to be back in operation very quickly in case of an internal fault. What's more, **the arc-killer's improved security features place less strict demands on the installation room**. As such, the Arc-Killer couples security and operational safety, with flexible room demands.

2. COMPARTMENTS

2.1. SWITCH COMPARTMENT

In this compartment, the SF₆-filled RV44 load break switch of the “sealed for life” type, acts as the physical separation between the busbar set and the cable compartment. The switch has two functions: it connects or interrupts the electrical current between the high voltage cables and the busbar.

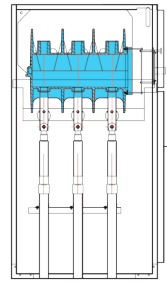

2.2. BUSBAR COMPARTMENT

The busbar compartment is located in the upper part of the cubicle and behind the low-voltage compartment. The modular busbar set is manufactured from specially provided electrolyte F25 copper of 60 x 10 mm with n = 5 mm (800 A). Several cubicles are connected through the bar set compartments. Hexagonal bolts connect the busbars to the upper contact surfaces of the RV44 load break switch.

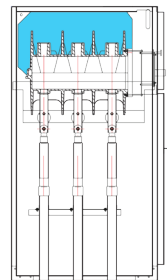

2.3. CABLE / CIRCUIT BREAKER / FUSE COMPARTMENT

This compartment is located behind the interlocked, removable door of the DF-2 cubicle. This part of the field receives the cable(s) and contains the necessary equipment to connect the cable(s). The earthing switch is installed below the load break switch on the right side, ensuring a “visible earthing” when the earthing switch is closed. In a DF-A cubicle, the cables are connected to the contact points below the RV44 load break switch. The cables of the DF-P cubicles are connected to the lower fuse base side. This type of cubicle also has an additional auxiliary earthing switch to divert any residual current. DF-D types have the earthing switches located in the cable compartment below. The removable door, the sectional floor panels, which house the necessary conductive rubber for the cables, and the cable supports, all simplify the cable connection.

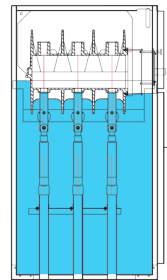

2.4. LOW-VOLTAGE COMPARTMENT

The drive mechanism that controls the RV44 load break switch and the earthing switch EM20 is fitted with the synoptic diagram and is located behind the front panel. Several accessories, such as the auxiliary contacts, switch-on or switch-off coils, and minimum voltage relays, are also located in this compartment. Any engine control with the necessary electrical switchgear, a control and clamp strip are also installed in this compartment. The compartment can be accessed very easily by removing the front panel.

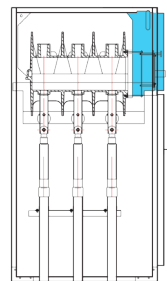

3. DF-2 MODULES RANGE

3.1. TECHNICAL SPECIFICATIONS

Rated Voltage	kV	12	17,5	24
Impulse withstand voltage 1.2 / 50 μ s				
- To earth and between phases	kV	75	95	125
- Over the insulated distance	kV	85	110	145
Power frequency withstand voltage:				
- To earth and between phases	kV	28	38	50
- Over the insulated distance	kV	32	45	60
Rated frequency	Hz	50/60	50/60	50/60
Rated current	A	800/1250(*)	800/1250(*)	630/800
Rated short-time current 1-2-3 s.	kA	25	25	20
Rated peak value of the current	kA	63	63	50
Breaking capacity RV44 (Class E3)				
- Mainly active load	A	800/1250(*)	800/1250(*)	630/800
- Closed loop	A	800	800	630/800
- Load cable charging	A	18	18	18
- Making current	kA	63	63	50
- Earth fault	A	100	100	100
- Earth fault cable charging	A	30	30	30
Internal arc 1 s.	kA	16/20/25(**)	16/20/25(**)	16/20/25(**)
Degree of protection		IP4X		
Mechanical durability c/o		1000		
Standards		IEC 62271-100, IEC 62271-1, 62271-102, -103, -105, 62271-200 and IEC 61243-5		
Certificates		KEMA/IPH		

(*) According to IEC 62271-103, Class E1
(**) Option arc-killer

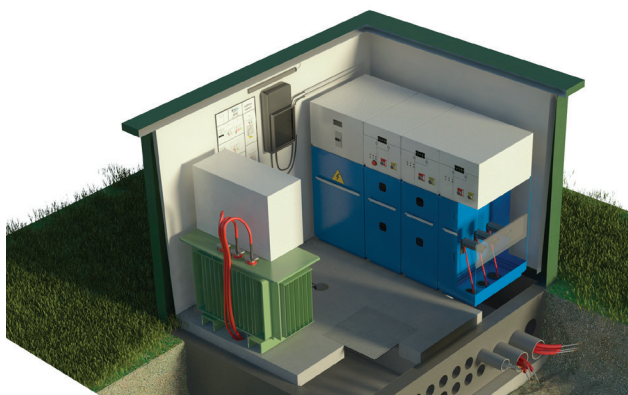

3.2. EXTENSIVE SPECIFICATIONS

Cubicles consist of 2 mm galvanized steel plates. By opting for this particular plate size, the cubicles are able to withstand internal arcs effortlessly, both in the cable compartment as well as in the busbar compartment.

A lot of detail went into the functional design to ensure that, in the event of an internal malfunction, no bursts of flames can move between plating surfaces, the door or between cubicles.

Possible internal arcs are also guaranteed to be restricted to the compartment where they originated.

The roof of the cubicle can be easily dismantled to provide smooth access to the busbar during installation and/or maintenance activities. The copper busbar is manufactured to resist the current, which results in minimum heating at the contact points.

The user-friendly construction of the drive mechanisms easily allows for optional features to be installed at a later stage. Optional features can even be installed without taking the cubicle out of service.

SGC - SwitchGear Company's countless years of experience resulted in a cable compartment as comfortable and as functional as possible. Thanks to the removable door, the operator has maximum access to the connection points. This is crucial when (dis)assembling cables and fuses, and during maintenance work. Moreover, it will save time and lead to less industrial accidents.

All connection points and fuse holders have been manufactured from rounded materials to make connecting parts as easy and as safe as possible. The earthing copper has been neatly stored behind folded panels and in no way affects the connection activities.

The high voltage cables can be supported by cable supports and the connection point in every type of cubicle is located high enough to install the terminals in the cubicle

Manual operation of the cubicles requires minimal switch force. The clean and neat synoptic diagram provides a clear and safe overview of the different positions of the various parts of the cubicle.

The accessories (such as floor panels and busbars) are stored in boxes and ensure easy assembling of the cubicles. The cubicles and their corresponding parts can be equipped with a wide range of optional features on request, in order to offer expert solutions to your needs.



“The cubicles can be equipped with a wide range of optional features...”

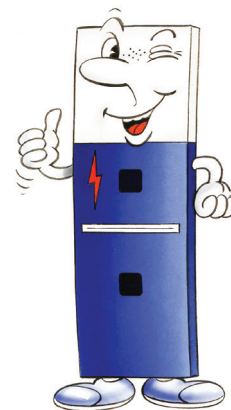

OTHER OPTIONS & DIMENSIONS?

Please consult us for options and dimensions other than those mentioned in this catalogue.

3.3. MODULES - SPECIFICATIONS & DIMENSIONS

DF-A	Incoming cubicle or cable field with load break switch RV44 and interlocked earthing switch.	p. 18
DF-A⁺	Incoming cubicle or cable field with load break switch RV44 and interlocked earthing switch with arc-killer and gas exhaust duct.	p. 19
DF-P	Protection cubicle with load break switch/fuse combination.	p. 20
DF-AV2	Protection cubicle for auxiliary voltage 2 phase.	p. 21
DF-AV3	Protection cubicle for auxiliary voltage 3 phase.	p. 22
DF-D	Protection cubicle with vacuum circuit breaker with integrated protection relay on the circuit breaker.	p. 23
DF-D/EDN	Protection cubicle with vacuum circuit breaker with block current transformers and separate relay of any make.	p. 24
DF-D⁺	Protection cubicle with vacuum circuit breaker with integrated protection relay on the circuit breaker with arc-killer and gas exhaust duct.	p. 25
DF-D⁺/EDN	Protection cubicle with vacuum circuit breaker with block current transformers, separate relay of any make, arc-killer and gas exhaust duct.	p. 26
DF-D500	Protection cubicle with removable vacuum circuit breaker and integrated protection relay.	p. 27

DF-DT

Protection cubicle with vacuum circuit breaker (magnetic driven).

p. 28

DF-DT + vt

Protection cubicle with vacuum circuit breaker (magnetic driven) and voltage transformer.

p. 29

DF-AAD

Protection cubicle with double interruption and integrated protection relay.

p. 30

DF-AAD ESW

Protection cubicle with double interruption, integrated protection relay and earthing switch.

p. 31

DF-AAD⁺

Protection cubicle with double interruption, integrated protection relay, arc-killer and gas exhaust duct.

p. 32

DF-AAD⁺ ESW

Protection cubicle with double interruption, integrated protection relay, arc-killer, gas exhaust duct and earthing switch.

p. 33

DF-AAD/EDN

Protection cubicle with double interruption and protection relay in low voltage compartment.

p. 34

DF-AAD⁺/EDN

Protection cubicle with double interruption, protection relay in low voltage compartment, arc-killer and gas exhaust duct.

p. 35

DF-AAD/EDN ESW

Protection cubicle with double interruption, protection relay in low voltage compartment and earthing switch.

p. 36

DF-AAD⁺/EDN ESW

Protection cubicle with double interruption, protection relay in low voltage compartment, arc-killer, gas exhaust duct and earthing switch.

p. 37

DF-AAADT	Protection cubicle with double interruption and circuit breaker (magnetic driven).	p. 38
DF-AAADT + vt	Protection cubicle with double interruption, circuit breaker (magnetic driven) and voltage transformer.	p. 39
DF-LK	Busbar coupling cubicle.	p. 40
DF-LKK	Busbar coupling cubicle with cable.	p. 41
DF-LKE	Busbar coupling cubicle with earthing switch.	p. 42
DF-LKKE	Busbar coupling cubicle with cable and earthing switch.	p. 43
DF-T	Transformer housing.	p. 44
DF-C-750	Metering cubicle.	p. 46
DF-C-500	Metering cubicle (SF ₆ gas).	p. 50
DF-LKB	Coupling cubicle.	p. 52

DF-DKB

Coupling cubicle bridge.

p. 53

DF-K

Cable cubicle.

p. 54

DF-K ESW

Cable cubicle and earthing switch.

p. 55

DF-K⁺ ESW

Cable cubicle with arc-killer, gas exhaust duct and earthing switch.

p. 56



DF-A

Incoming cubicle or cable field with load break switch RV44 and interlocked earthing switch.

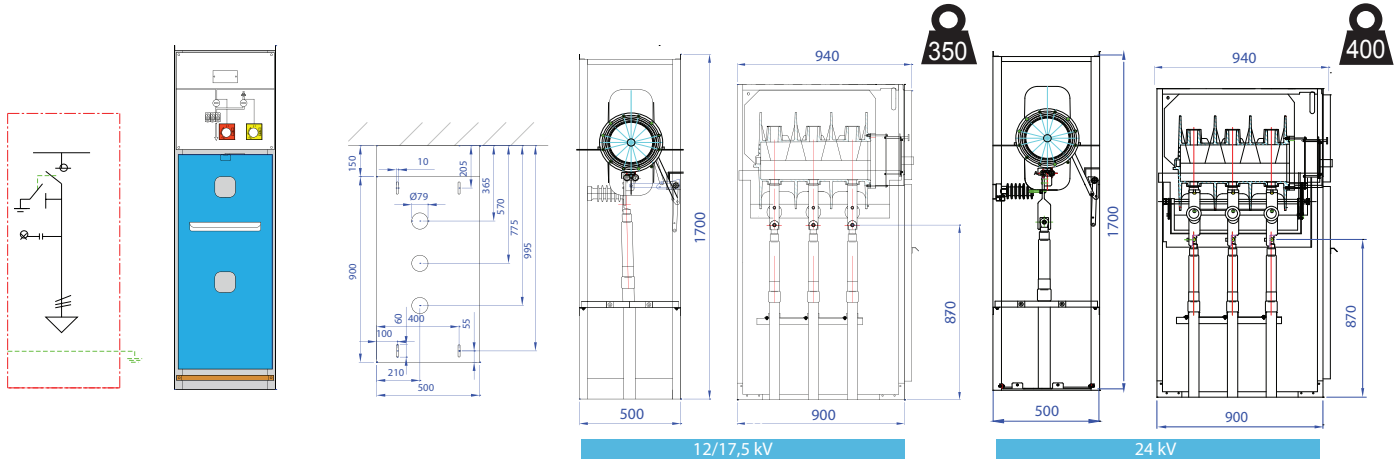

Standard Equipment

- Triple-phase load break switch RV44, class E3 according to IEC 62271-103, SF₆-insulation
- Interlocked earthing switch with making capacity up to 63 kA
- Cable support
- Door interlock
- Insulators with capacitive device for VDS (Voltage Detection System)
- Low-voltage compartment
- Floor panels

Cubicle Options

- Set of auxiliary contacts on load break switch
- Set of auxiliary contacts on earthing switch
- Key interlock on load break switch
- Key interlock on earthing switch
- Key interlock on both
- No door interlock
- Motor operation: 24-48-110 V - AC/DC of 220 V AC
- Short-circuit indicator (to be specified by the customer when the order is placed)
- Voltage indicators: VDS - LRM (*) - HR (***) (to be confirmed at order)
- Cubicle base: 200 mm, 300 mm or 400 mm height (Other dimensions on request)
- Button press control
- Remote control

APPLICATION

Supply cable connection.

SPECIFICATIONS & DIMENSIONS

Rated Voltage	kV	12	17,5	24
Rated current	A	800/1250	800/1250	630/800
Short-term current	kA	25	25	20
Time of the short duration of current	s	1	1	1
Width	mm	500	500	500
Depth	mm	1050	1050	1050
Height	mm	1700	1700	1700
Height between ground and end socket	mm	945	945	835
Height between ground and cable support	mm	445	445	445
Weight	kg	350	350	400

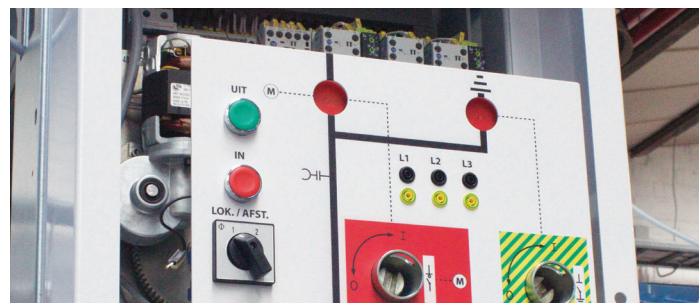

(*) Low resistance measurement
(***) High resistance measurement

DF-A+

Incoming cubicle or cable field with load break switch RV44 and interlocked earthing switch with arc-killer and gas exhaust duct.

380

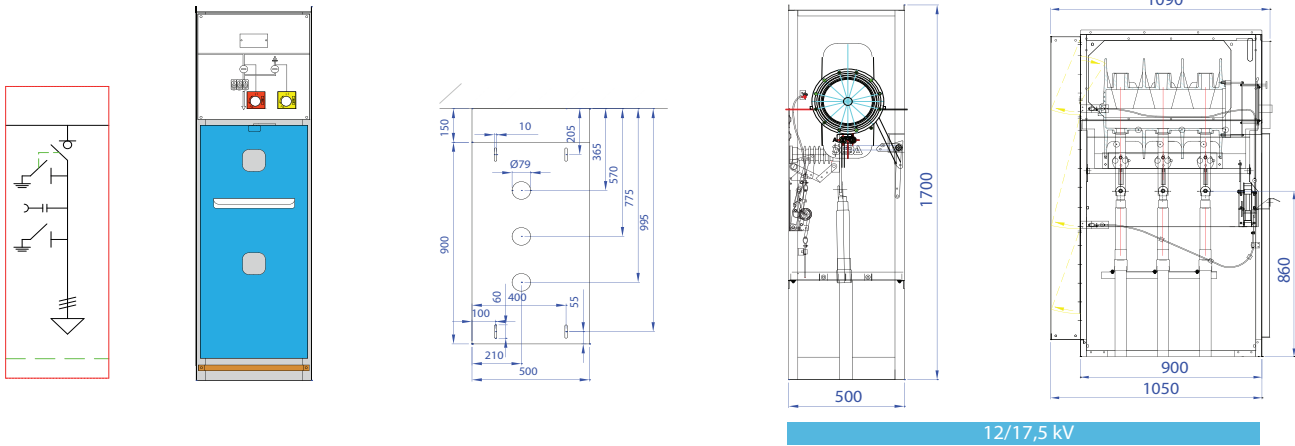

Standard Equipment

- Triple-phase load break switch RV44, class E3 according to IEC 62271-103, SF₆-insulation
- Interlocked earthing switch with making capacity up to 63 kA
- Cable support
- Door interlock
- Insulators with capacitive device for VDS (Voltage Detection System)
- Low-voltage compartment
- Arc-killer SV-25 built-in
- Gas exhaust duct at rear of the cubicle
- Floor panels

Cubicle Options

- Set of auxiliary contacts on load break switch
- Set of auxiliary contacts on earthing switch
- Key interlock on load break switch
- Key interlock on earthing switch
- Key interlock on both
- No door interlock
- Motor operation: 24-48-110 V - AC/DC of 220 V AC
- Short-circuit indicator (to be specified by the customer when the order is placed)
- Voltage indicators VDS - LRM (*) - HR (***) (to be confirmed at order)
- Cubicle base 200 mm, 300 mm or 400 mm height (Other dimensions on request)
- Button press control
- Remote control

(*) Low resistance measurement
 (***) High resistance measurement

APPLICATION

Supply cable connection.

SPECIFICATIONS & DIMENSIONS

Rated Voltage	kV	12	17,5
Rated current	A	800/1250	800/1250
Short-term current	kA	25	25
Time of the short duration of current	s	1	1
Width	mm	500	500
Depth	mm	1050	1050
Height	mm	1700	1700
Weight	kg	380	380

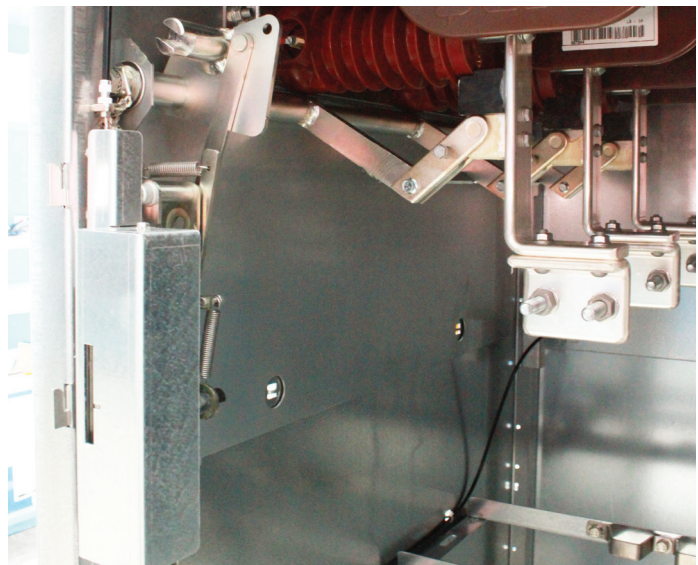

Arc-Killer

DF-P

Protection cubicle with load break switch/fuse combination.

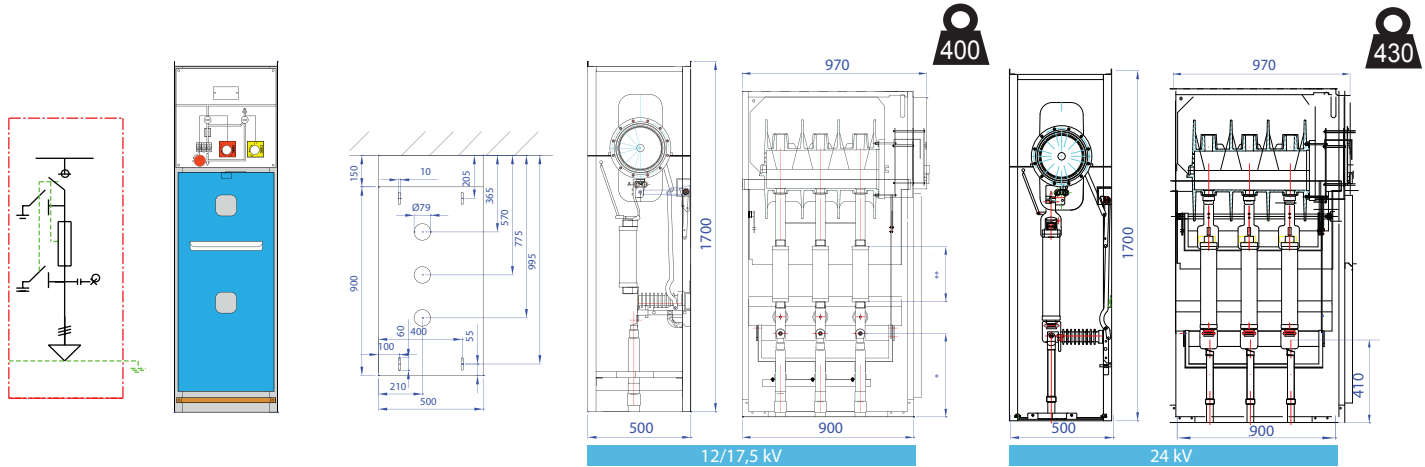

Standard Equipment

- Triple-phase load break switch RV44, class E3 according to IEC 62271-105, SF₆-insulation
- Double earthing switch with mutual interlock
- Socket for HRC fuses:
 - e = 292 mm DIN 10 at 17.5 kV
 - e = 442 mm DIN 20 at 24 kV
 - UTE
- Triple-pole fuse trip
- Switch-off mechanism through hitting bolt
- Door interlock
- Insulators with capacitive device for VDS (Voltage Detection System)
- Low-voltage compartment
- Floor panels

Cubicle Options

- Set of auxiliary contacts on load break switch
- Set of auxiliary contacts on earthing switch
- Key interlock on load break switch
- Key interlock on the earthing switch
- Key interlock on both
- Shunt trip (*)
- Under voltage release (*)
- Closing release (*)
- Motor operation (*)
- HRC fuses and/or spare fuses
- Contact "fuse blown"
- Automatic recloser
- Voltage indicators VDS - LRM (***) - HR (***) (to be confirmed at order)
- Cubicle base: 200 mm, 300 mm or 400 mm height (other dimensions on demand)
- Button press control
- Remote control

(*) Available voltages: 24 V AC/DC, 48 V AC/DC, 110 V AC/DC, 220 V AC

(**) Low resistance measurement

(***) High resistance measurement

APPLICATION

Transformer protection and MV-equipment protection.

SPECIFICATIONS & DIMENSIONS

Rated Voltage	kV	12	17,5	24
Rated current	A	800/1250 ^(*)	800/1250 ^(*)	630/800
Short-term current	kA	25	25	20
Time of the short duration of current	s	1	1	1
Width	mm	500	500	500
Depth	mm	1050	1050	1050
Height	mm	1700	1700	1700
Height between ground and end socket	mm	460	460	415
Fuse size	mm	292 (DIN)	292 (DIN)	442 (DIN)/UTE
Weight	kg	400	400	430

(*) Max I_n through fusecontacts: 63A



DF-AV2

Protection cubicle for auxiliary voltage 2 phase

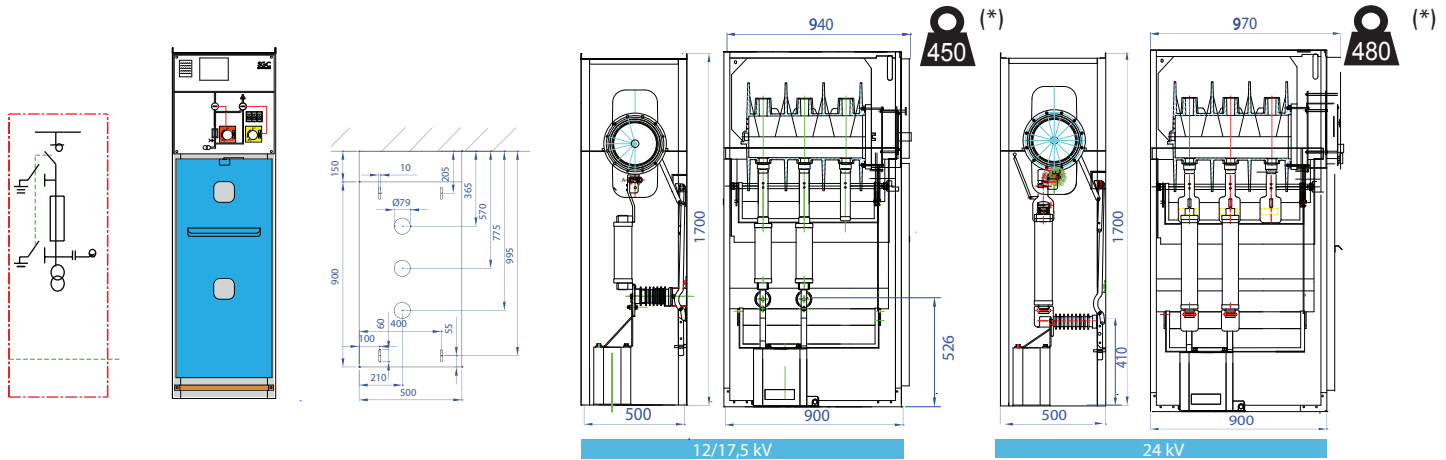

Standard Equipment

- Triple-phase load break switch RV44, class E3 according to IEC 62271-103, interruption medium SF₆
- Double interlocked earthing switch
- HRC fuse-holders:
 - e = 292 mm DIN 10 at 17.5 kV
 - e = 442 mm DIN 20 at 24 kV
 - UTE
- Door interlock
- Insulators with capacitive device for VDS (Voltage Detection System)
- Low-voltage compartment
- Assembly plate for auxiliary transformer(s)

Cubicle Options

- Set of auxiliary contacts on load break switch
- Set of auxiliary contacts on earthing switch
- Key interlock on load break switch
- Key interlock on earthing switch
- Key interlock on both devices
- Motor operation (*)
- HRC fuses or spare fuses
- Auxiliary contact "fuse link burned"
- Set of 1, 2 or 3 voltage transformers
- Voltage indicator VDS - LRM (**) - HR (***) (to be confirmed at order)
- Cubicle base: 200 mm, 300 mm or 400 mm height (other dimensions on demand)
- Button press control
- Remote control
- VT: xx kV/x V x VA CL.XX

(*) Available voltages: 24 V AC/DC, 48 V AC/DC, 110 V AC/DC, 220 V AC

(**) Low resistance measurement

(***) High resistance measurement

APPLICATION

Auxiliary voltage feeding or network survey.

SPECIFICATIONS & DIMENSIONS

Rated Voltage	kV	12	17,5	24
Rated current	A	6,3	6,3	6,3
Short-term current	kA	25	25	20
Time of the short duration of current	s	1	1	1
Width	mm	500	500	500
Depth	mm	1050	1050	1050
Height	mm	1700	1700	1700
Fuse size	mm	292 (DIN)	292 (DIN)	442 (DIN)/UTE
Weight (*)	kg	450	450	480

(*) Overload due to VTs and number of fuse holders may vary from 35 to 150 kg

OTHER OPTIONS & DIMENSIONS?

Please consult us for options and dimensions other than those mentioned in this catalogue.

DF-AV3

Protection cubicle for auxiliary voltage 3 phase

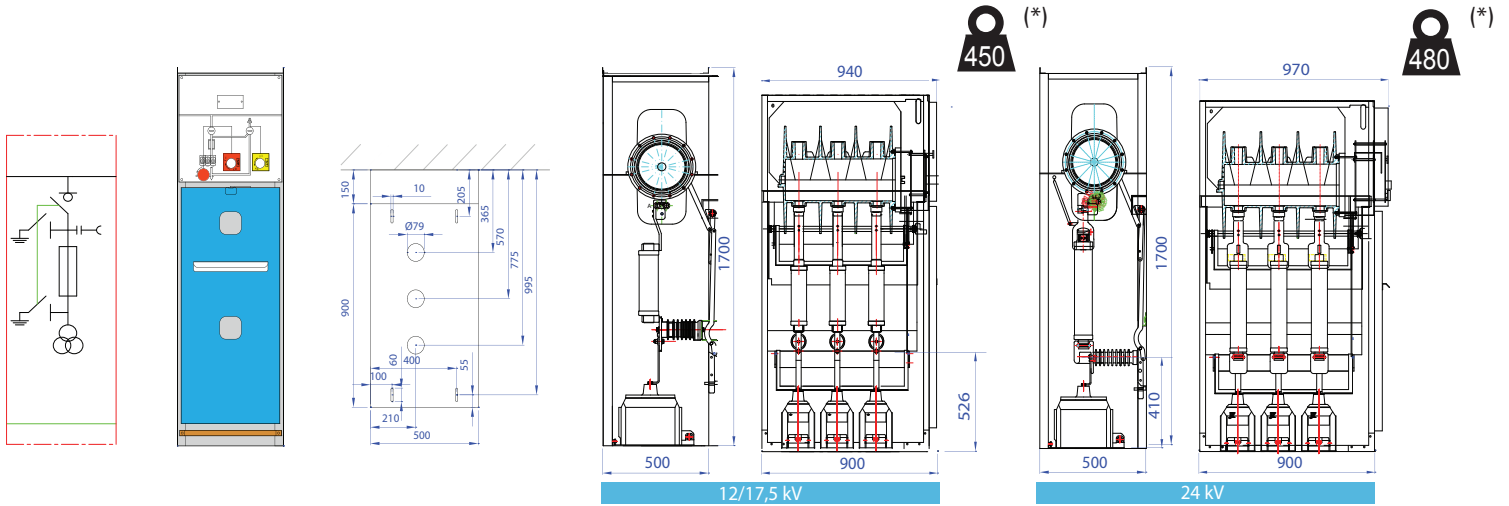

Standard Equipment

- Triple-phase load break switch RV44, class E3 according to IEC 62271-103, interruption medium SF₆
- Double interlocked earthing switch
- HRC fuse-holders:
 - e = 292 mm DIN 10 at 17.5 kV
 - e = 442 mm DIN 20 at 24 kV
 - UTE
- Door interlock
- Insulators with capacitive device for VDS (Voltage Detection System)
- Low-voltage compartment
- Assembly plate for auxiliary transformer(s)

Cubicle Options

- Set of auxiliary contacts on load break switch
- Set of auxiliary contacts on earthing switch
- Key interlock on load break switch
- Key interlock on earthing switch
- Key interlock on both devices
- Motor operation (*)
- HRC fuses or spare fuses
- Auxiliary contact "fuse link burned"
- Set of 1, 2 or 3 voltage transformers
- Voltage indicators VDS - LRM (**) - HR (***) (to be confirmed at order)
- Cubicle base: 200 mm, 300 mm or 400 mm height (other dimensions on demand)
- Button press control
- Remote control
- VT: xx kV/x V x VA CL.XX

(*) Available voltages: 24 V AC/DC, 48 V AC/DC, 110 V AC/DC, 220 V AC

(**) Low resistance measurement

(***) High resistance measurement

APPLICATION

Auxiliary voltage feeding or network survey.

SPECIFICATIONS & DIMENSIONS

Rated Voltage	kV	12	17,5	24
Rated current	A	6,3	6,3	6,3
Short-term current	kA	25	25	20
Time of the short duration of current	s	1	1	1
Width	mm	500	500	500
Depth	mm	1050	1050	1050
Height	mm	1700	1700	1700
Fuse size	mm (DIN)	292 (DIN)	292 (DIN)	442 (DIN)/UTE
Weight (*)	kg	450	450	480

(*) Overload due to VTs and number of fuse holders may vary from 35 to 150 kg

OTHER OPTIONS & DIMENSIONS?

Please consult us for options and dimensions other than those mentioned in this catalogue.

DF-D

Protection cubicle with vacuum circuit breaker with integrated protection relay on the circuit breaker.

460

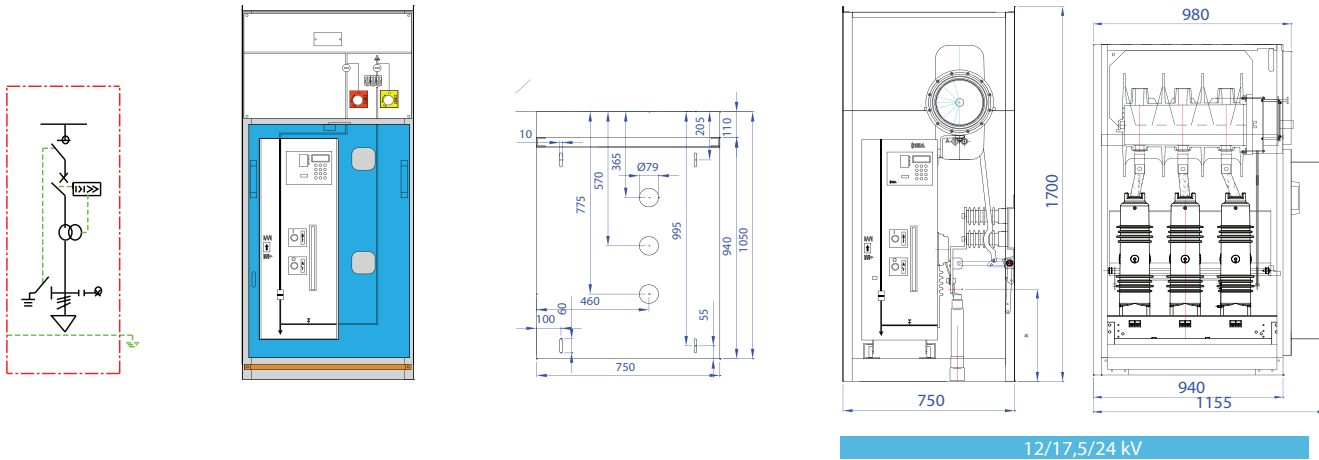

Standard Equipment

- Triple-phase load break switch RV44, class E3 according to IEC 62271-103, SF₆-insulation
- Vacuum circuit breaker with integrated dual powered protection relay, current transformers and open release
- Interlocked earthing switch with rated making capacity up to 63 kA downstream of the capacity switch
- Cable support
- Door interlock
- Insulators with capacitive device for VDS (Voltage Detection System)
- Voltage indicators VDS - LRM (*) - HR (**) (to be confirmed at order)
- Switch counter
- LV compartment
- Floor panels

Cubicle Options

- Set of auxiliary contacts on the load break switch
- Set of auxiliary contacts on the earthing switch
- Key interlock on load break switch
- Key interlock on earthing switch
- Key interlock on both
- No door interlock
- Motor operation on load break switch: 24-48-110 V AC/DC & 220 V AC
- Earthing connections upwards from the circuit breaker
- Voltage indicators: VDS - LRM (*) - HR (**) (to be confirmed at order)
- Cubicle base: 200 mm, 300 mm or 400 mm height (other dimensions on demand)
- Button press control on switch-disconnector
- Remote control on switch-disconnector

(*) Low resistance measurement
(**) High resistance measurement

APPLICATION

Protection of feeders with circuit breaker, transformer and MV-equipment protection.

SPECIFICATIONS & DIMENSIONS

Rated Voltage	kV	12	17,5	24
Rated current	A	800/1250	800/1250	630/800
Short-term current	kA	25	25	20
Time of the short duration of current	s	1	1	1
Width	mm	750	750	750
Depth	mm	1050	1050	1050
Height	mm	1700	1700	1700
Height between ground and socket	mm	445	445	445
Weight	kg	460	460	460

Options on the circuit breaker

- Motor operation (*)
- Closing release
- Shunt trip 1-2 (*)
- Delayed/ direct Under voltage release (*)
- Set of auxiliary contacts from 1-6
- Fault contact on the relay
- Supply for test protective relay (battery block)
- Automatic recloser
- Remote control on circuit breaker
- Key interlock with load break switch and with earthing switch
- Indication lamps
- Pushbuttons close-open

Specifications to be indicated for circuit-breaker VA-2/VAS-2: Short-circuit capacity, rated current, rated voltage and capacity to be secured

(*) Available voltages: 24 V AC/DC, 48 V AC/DC, 110 V AC/DC, 220 V AC

DF-D/EDN

Protection cubicle with vacuum circuit breaker with block current transformers and separate relay of any make.

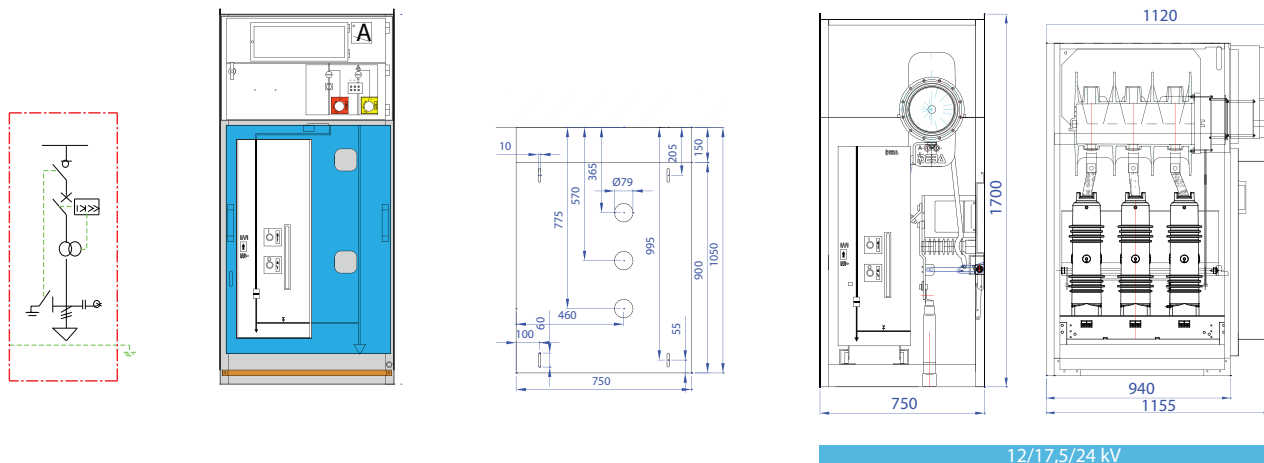

Standard Equipment

- Triple-phase load break switch RV44, class E3 according to IEC 62271-103, SF₆-insulation
- Vacuum circuit breaker
- Interlocked earthing switch with rated making capacity up to 63 kA downstream of the capacity switch
- Cable support
- Door interlock
- Insulators with capacitive device for VDS (Voltage Detection System)
- Voltage indicators VDS - LRM^(*) - HR^(**) (to be confirmed at order)
- Switch counter
- LV compartment accessible by door
- Floor panels
- Base for 3 current transformers block type

Cubicle Options

- Protection relay (to be specified by the customer)
- Current transformer (to be specified by the customer)
- Set of auxiliary contacts on the load break switch
- Set of auxiliary contacts on the earthing switch
- Key interlock on load break switch
- Key interlock on earthing switch
- Key interlock on both
- No door interlock
- Motor operation on load break switch: 24-48-110 V AC/DC & 220 V AC
- Earthing connections upwards from the circuit breaker
- Cubicle base: 200 mm, 300 mm or 400 mm height (other dimensions on demand)
- Button press control on switch-disconnector
- Remote control on switch-disconnector
- Torus current transformer

^(*) Low resistance measurement
^(**) High resistance measurement

APPLICATION

Protection of feeders with circuit breaker, transformer and MV-equipment protection.

SPECIFICATIONS & DIMENSIONS

Rated Voltage	kV	12	17,5	24
Rated current	A	800/1250	800/1250	630/800
Short-term current	kA	25	25	20
Time of the short duration of current	s	1	1	1
Width	mm	750	750	750
Depth	mm	1050	1050	1050
Height	mm	1700	1700	1700
Height between ground and socket	mm	445	445	445
Weight	kg	460	460	460

Options on the circuit breaker

- Motor operation^(*)
- Closing release
- Shunt trip 1-2^(*)
- Delayed/ direct Under voltage release^(*)
- Set of auxiliary contacts from 1-6
- Fault contact on the relay
- Supply for test protective relay (battery block)
- Automatic recloser
- Remote control on circuit breaker
- Key interlock with load break switch and with earthing switch
- Indication lamps
- Pushbuttons close-open

Specifications to be indicated for circuit-breaker VA-2/VAS-2: Short-circuit capacity, rated current, rated voltage and capacity to be secured

^(*) Available voltages: 24 V AC/DC, 48 V AC/DC, 110 V AC/DC, 220 V AC

DF-D+

Protection cubicle with vacuum circuit breaker with integrated protection relay on the circuit breaker with arc-killer and gas exhaust duct.

490

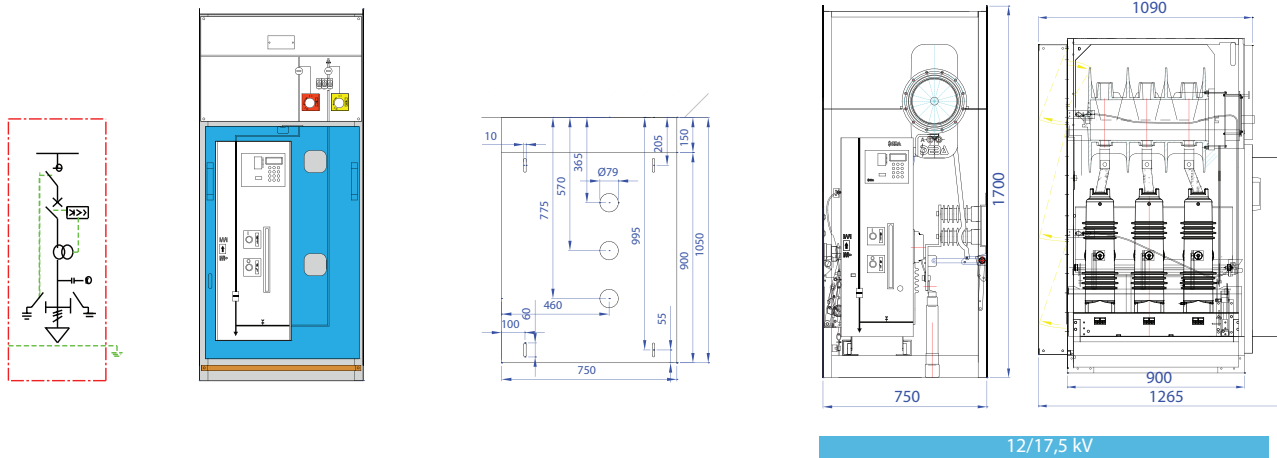

Standard Equipment

- Triple-phase load break switch RV44, class E3 according to IEC 62271-103, SF₆-insulation
- Vacuum circuit breaker with integrated dual powered protection relay, current transformers and open release
- Interlocked earthing switch with rated making capacity up to 63 kA downstream of the capacity switch
- Cable support
- Door interlock
- Insulators with capacitive device for VDS (Voltage Detection System)
- Voltage indicators VDS - LRM (*) - HR (**)(to be confirmed at order)
- LV compartment
- Switch counter
- Arc-killer SV-25 inside
- Gas exhaust duct at the rear of the cubicle
- Floor panels

Cubicle Options

- Set of auxiliary contacts on the load break switch
- Set of auxiliary contacts on the earthing switch
- Key interlock on load break switch
- Key interlock on earthing switch
- Key interlock on both
- No door interlock
- Motor operation on load break switch: 24-48-110 V AC/DC & 220 V AC
- Earthing connections upwards from the circuit breaker
- Voltage indicators: VDS - LRM (*) - HR (**)(to be confirmed at order)
- Cubicle base: 200 mm, 300 mm or 400 mm height (other dimensions on demand)
- Button press control on switch-disconnector
- Remote control on switch-disconnector

(*) Low resistance measurement
(**) High resistance measurement

APPLICATION

Protection of feeders with circuit breaker, transformer and MV-equipment protection.

SPECIFICATIONS & DIMENSIONS

Rated Voltage	kV	12	17,5
Rated current	A	800/1250	800/1250
Short-term current	kA	25	25
Time of the short duration of current	s	1	1
Width	mm	750	750
Depth	mm	1050	1050
Height	mm	1700	1700
Height between ground and socket	mm	445	445
Weight	kg	490	490

Options on the circuit breaker

- Motor operation (*)
- Closing release
- Shunt trip 1-2 (*)
- Delayed/ direct Under voltage release (*)
- Set of auxiliary contacts from 1-6
- Fault contact on the relay
- Supply for test protective relay (battery block)
- Automatic recloser
- Remote control on circuit breaker
- Key interlock with load break switch and with earthing switch
- Indication lamps
- Pushbuttons close-open

Specifications to be indicated for circuit-breaker VA-2/VAS-2: Short-circuit capacity, rated current, rated voltage and capacity to be secured

(*) Available voltages: 24 V AC/DC, 48 V AC/DC, 110 V AC/DC, 220 V AC

DF-D+/EDN

Protection cubicle with vacuum circuit breaker with block current transformers, separate relay of any make with arc-killer and gas exhaust duct.

490

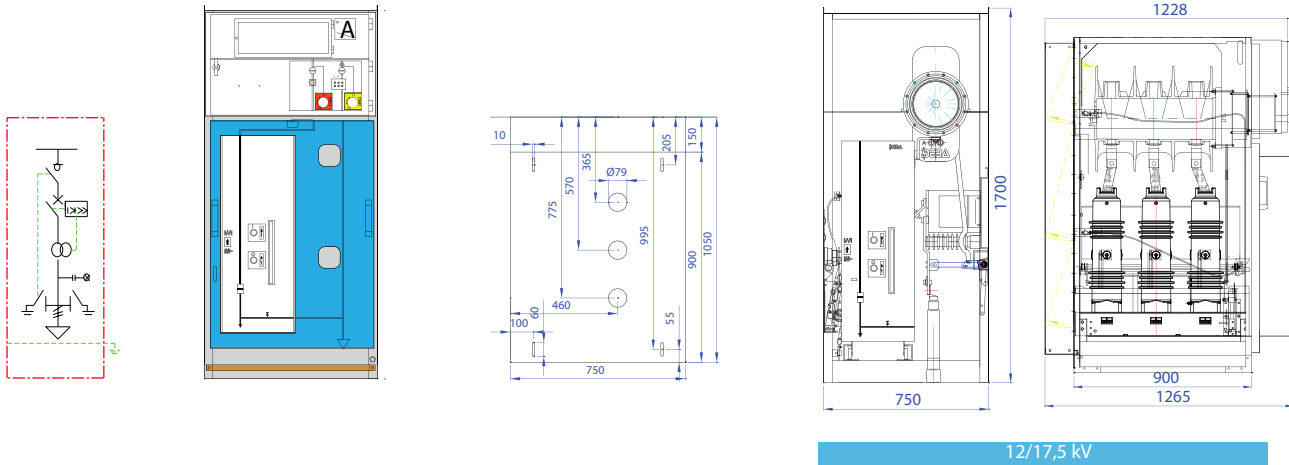

Standard Equipment

- Triple-phase load break switch RV44, class E3 according to IEC 62271-103, SF₆-insulation
- Vacuum circuit breaker
- Interlocked earthing switch with rated making capacity up to 63 kA downstream of the capacity switch
- Cable support
- Door interlock
- Insulators with capacitive device for VDS (Voltage Detection System)
- Voltage indicators VDS - LRM^(*) - HR^(**) (to be confirmed at order)
- Switch counter
- LV compartment accessible by door
- Floor panels
- Arc-Killer SV-25 inside
- Gas exhaust duct at the rear of the cubicle
- Base for 3 current transformers block type

Cubicle Options

- Protection relay (to be specified by the customer)
- Current transformer (to be specified by the customer)
- Set of auxiliary contacts on the load break switch
- Set of auxiliary contacts on the earthing switch
- Key interlock on load break switch
- Key interlock on earthing switch
- Key interlock on both
- No door interlock
- Motor operation on load break switch: 24-48-110 V AC/DC & 220 V AC
- Earthing connections upwards from the circuit breaker
- Cubicle base: 200 mm, 300 mm or 400 mm height (other dimensions on demand)
- Button press control on switch-disconnector
- Remote control on switch-disconnector
- Torus current transformer

^(*) Low resistance measurement

^(**) High resistance measurement

APPLICATION

Protection of feeders with circuit breaker, transformer and MV-equipment protection.

SPECIFICATIONS & DIMENSIONS

Rated Voltage	kV	12	17,5
Rated current	A	800/1250	800/1250
Short-term current	kA	25	25
Time of the short duration of current	s	1	1
Width	mm	750	750
Depth	mm	1050	1050
Height	mm	1700	1700
Height between ground and socket	mm	445	445
Weight	kg	490	490

Options on the circuit breaker

- Motor operation^(*)
- Closing release
- Shunt trip 1-2^(*)
- Delayed/ direct Under voltage release^(*)
- Set of auxiliary contacts from 1-6
- Fault contact on the relay
- Supply for test protective relay (battery block)
- Automatic recloser
- Remote control on circuit breaker
- Key interlock with load break switch and with earthing switch
- indication lamps
- Pushbuttons close-open

Specifications to be indicated for circuit-breaker VA-2/VAS-2: Short-circuit capacity, rated current, rated voltage and capacity to be secured

^(*) Available voltages: 24 V AC/DC, 48 V AC/DC, 110 V AC/DC, 220 V AC

DF-D-500

Protection cubicle with removable vacuum circuit breaker and integrated protection relay.

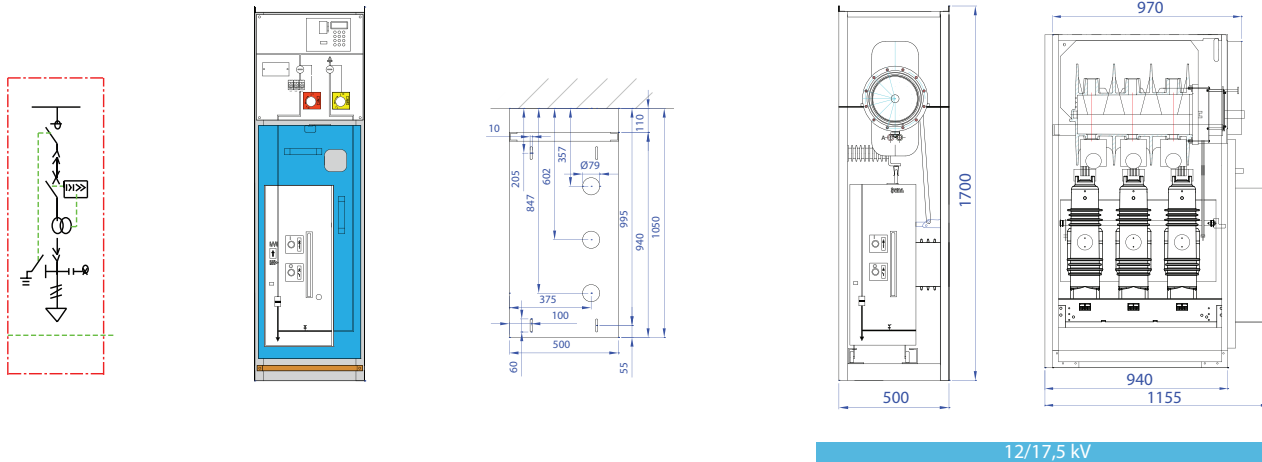

Standard Equipment

- Triple-phase load break switch RV44, class E3 according to IEC 62271-103, SF₆-insulation
- Vacuum circuit breaker with separate dual powered protection relay RP600, current transformers^(*) and opening release
- Interlocked earthing switch with rated making capacity up to 63 kA downstream of the capacity switch
- Cable support
- Door interlock
- Insulators with capacitive device for VDS (Voltage Detection System)
- Low voltage compartment
- Draw-out circuit breaker
- Floor panels
- Switch counter

Cubicle Options

- Set of auxiliary contacts on the load break switch
- Set of auxiliary contacts on the earthing switch
- Key interlock on load break switch
- Key interlock on earthing switch
- Key interlock on both
- No door interlock
- Motor operation on load break switch: 24-48-110 V AC/DC & 220 V AC
- Voltage indicators VDS - LRM^(**) - HR^(***) (to be confirmed at order)
- Cubicle base: 200 mm, 300 mm or 400 mm height (other dimensions on demand)
- Button press control on switch-disconnector
- Remote control on switch-disconnector
- Relay (to be specified by the customer)

(*) (Ratings of the CT's: 50 - 150 - 200 - 400 - 600 // 1A/2,5 VA)
 (**) Low resistance measurement
 (***) High resistance measurement

APPLICATION

Securing of feeders with draw-out circuit breaker allowing fast exchange of the circuit breaker (minimal downtime).

SPECIFICATIONS & DIMENSIONS

Rated Voltage	kV	12	17,5
Rated current	A	630	630
Short-term current	kA	25	25
Time of the short duration of current	s	1	1
Width	mm	500	500
Depth	mm	1050	1050
Height	mm	1700	1700
Height between ground and socket	mm	450	450
Weight	kg	400	400

Options on the circuit breaker

- Motor operation^(*)
- Closing release
- Shunt trip 1-2^(*)
- Delayed/ direct Under voltage release^(*)
- Set of auxiliary contacts from 1-6
- Fault contact on the relay
- Supply for test protective relay (battery block)
- Automatic recloser
- Remote control on circuit breaker
- Key interlock with load break switch and with earthing switch
- indication lamps
- Pushbuttons close-open

Specifications to be indicated for circuit-breaker VA-2/VAS-2:
 Short-circuit capacity, rated current, rated voltage and capacity to be secured

(*) Available voltages: 24 V AC/DC, 48 V AC/DC, 110 V AC/DC, 220 V AC

DF-DT

Protection cubicle with vacuum circuit breaker (magnetic driven).

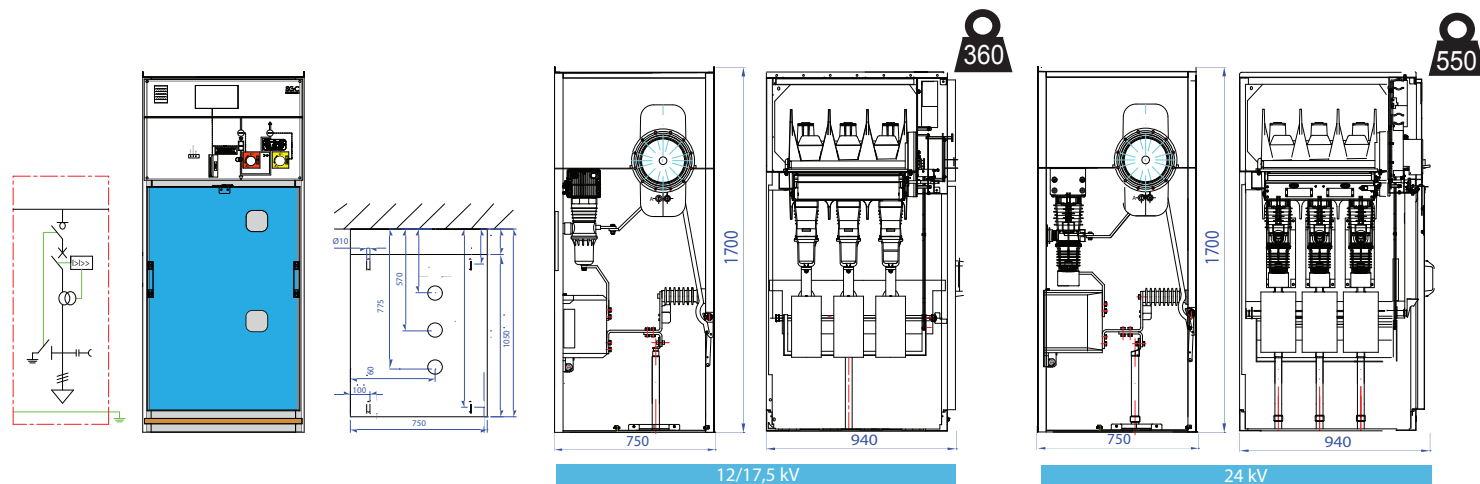

Standard Equipment

- Triple-phase load break switch RV44 - class E3 according to IEC 62271-103, SF₆ insulation
- Vacuum circuit breaker with magnetic drive
- Interlocked earthing switch with a rated making capacity up to 63 kA downstream of the circuit breaker
- Cable support structure
- Door interlock
- Insulators with capacitive device for VDS (Voltage Detection System)
- Voltage indicators: VDS - LRM (*) - HR (**) (to be confirmed at order)
- LV compartment
- Floor panels
- Current transformer

Cubicle Options

- Current transformer (to be specified by the customer)
- Voltage transformer (to be specified by the customer)
- Auxiliary contacts on the load break switch
- Auxiliary contacts on the earthing switch
- Key interlock on the load break switch
- Key interlock on the earthing switch
- Key interlock on both
- No door interlock
- Choice of auxiliary voltage: 24-48-110 VDC or 110-220 VAC
- Short circuit indicator (to be specified by the customer)
- Earthing connection upstream from the circuit breaker
- Cubicle base: 200, 300, 400 mm height (other dimensions on demand)
- Button press control on the load break switch
- Remote control of the load break switch

(*) Low resistance measurement
(**) High resistance measurement

APPLICATION

Protection of feeders with circuit breaker, voltage and current transformer and MV protection (max 1250 A).

SPECIFICATIONS & DIMENSIONS

Rated Voltage	kV	12	17,5	24
Rated current	A	800/1250	800/1250	630/800
Short-term current	kA	16/20/25	16/20/25	16
Time of the short duration of current	s	1/2/3	1/2/3	1/2/3
Width	mm	750	750	750
Depth	mm	940	940	940
Height	mm	1700	1700	1700
Height between ground and socket	mm	450	450	450
Weight	kg	360	360	550

Options on the circuit breaker

- Under-voltage release (electronic)
- Block auxiliary contacts
- Operation counter
- Reclosing function (standard)
- Remote control
- Interlock

Specifications to be indicated for circuit-breaker:
Short-circuit capacity, rated current, rated voltage and capacity to be secured

DF-DT + vt

Protection cubicle with vacuum circuit breaker (magnetic driven) and voltage transformer.

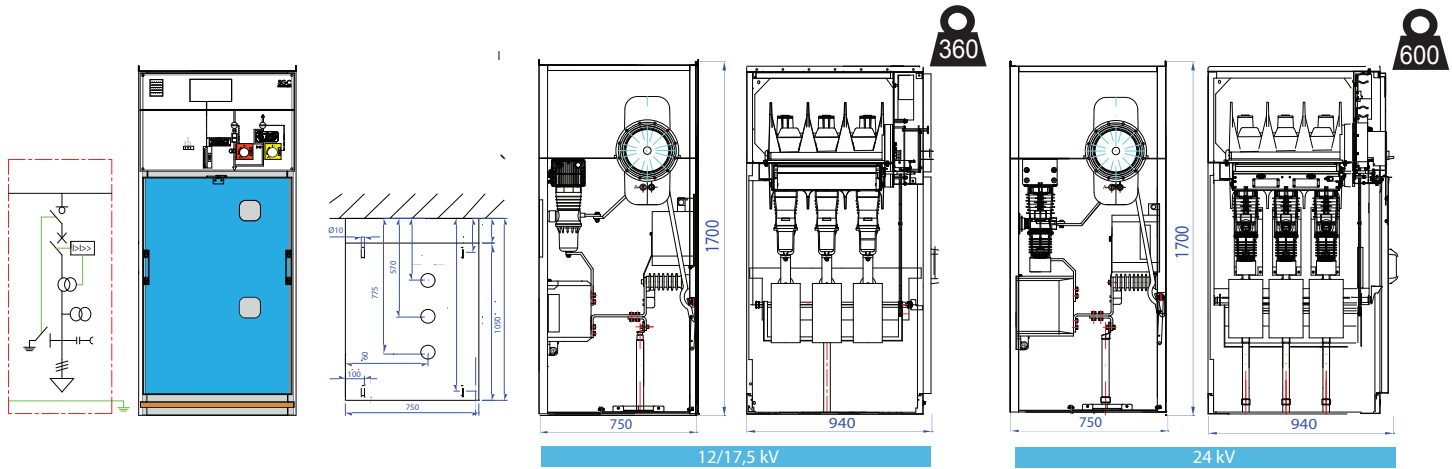

Standard Equipment

- Triple-phase load break switch RV44 - class E3 according to IEC 62271-103, SF₆ insulation
- Vacuum circuit breaker with magnetic drive
- Interlocked earthing switch with a rated making capacity up to 63 kA downstream of the circuit breaker
- Cable support structure
- Door interlock
- Insulators with capacitive device for VDS (Voltage Detection System)
- Voltage indicators: VDS - LRM (*) - HR (**) (to be confirmed at order)
- LV compartment
- Floor panels

Cubicle Options

- Current transformer (to be specified by the customer)
- Voltage transformer (to be specified by the customer)
- Auxiliary contacts on the load break switch
- Auxiliary contacts on the earthing switch
- Key interlock on the load break switch
- Key interlock on the earthing switch
- Key interlock on both
- No door interlock
- Choice of auxiliary voltage: 24-48-110 VDC or 110-220 VAC
- Short circuit indicator (to be specified by the customer)
- Earthing connection upstream from the circuit breaker
- Cubicle base: 200, 300, 400 mm height (other dimensions on demand)
- Button press control on the load break switch
- Remote control of the load break switch

APPLICATION

Protection of feeders with circuit breaker, voltage and current transformer and MV protection (max 1250 A).

SPECIFICATIONS & DIMENSIONS

Rated Voltage	kV	12	17,5	24
Rated current	A	800/1250	800/1250	630/800
Short-term current	kA	16/20/25	16/20/25	16
Time of the short duration of current	s	1/2/3	1/2/3	1/2/3
Width	mm	750	750	750
Depth	mm	940	940	940
Height	mm	1700	1700	1700
Height between ground and socket	mm	450	450	450
Weight	kg	360	360	600

Options on the circuit breaker

- Under-voltage release (electronic)
- Block auxiliary contacts
- Operation counter
- Reclosing function (standard)
- Remote control
- Interlock

Specifications to be indicated for circuit-breaker:
Short-circuit capacity, rated current, rated voltage and capacity to be secured

(*) Low resistance measurement

(**) High resistance measurement

DF-AAD

Protection cubicle with double interruption and integrated protection relay.

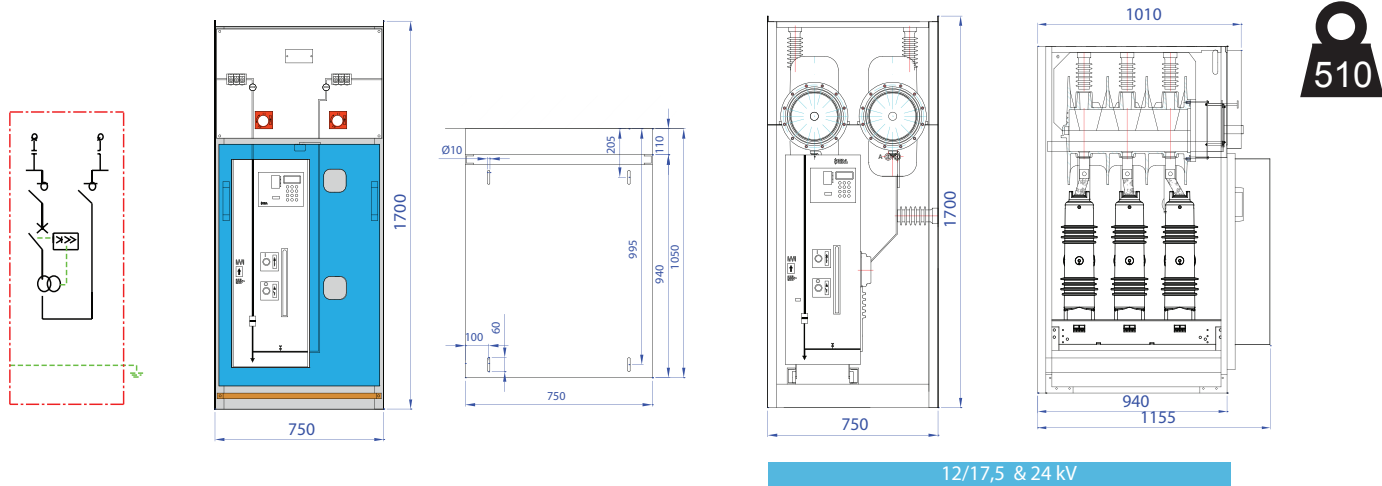

Standard Equipment

- Triple-phase load break switch RV44, class E3 according to IEC 62271-103, SF₆-insulation
- Vacuum circuit breaker with integrated protection relay
- Door interlock
- Low voltage compartment
- Insulators with capacitive device for VDS (Voltage Detection System)
- Holder for capacitive voltage indicators load break switch 1 and/or 2
- Floor panels

Cubicle Options

- Set of auxiliary contacts on load break switch 1 and/or 2
- Key interlock on load break switch 1 and/or 2
- Key interlock on earthing switch
- Mechanical interlock between the load break switches
- No door interlock
- Motor operation on load break switch 1 and/or 2: 24-48-110 V AC/DC & 220 V AC
- Earthing switch
- Earthing connections on load break switch 1 and/or 2
- Earthing connections outside of cubicle
- Capacitive voltage indicators load break switch 1 and/or 2
- Cubicle base: 200 mm, 300 mm or 400 mm height (other dimensions on demand)
- Button press control on load break switch 1 and/or 2
- Remote control on load break switch 1 and/or 2
- Current transformers

APPLICATION

Protection of descending feeders with transformer and MV-equipment provided with circuit breaker and double separation of busbar upstream and downstream.

SPECIFICATIONS & DIMENSIONS

Rated Voltage	kV	12	17,5	24
Rated current	A	800/1250	800/1250	630/800
Short-term current	kA	25	25	20
Time of the short duration of current	s	1	1	1
Width	mm	750	750	750
Depth	mm	1050	1050	1050
Height	mm	1700	1700	1700
Weight	kg	510	510	510

Options on the circuit breaker

- Motor operation (*)
- Closing release
- Shunt trip 1-2 (*)
- Delayed/ direct Under voltage release (*)
- Set of auxiliary contacts from 1-6
- Fault contact on the relay
- Supply for test protective relay (battery block)
- Automatic recloser
- Remote control on circuit breaker
- Key interlock with load break switch and with earthing switch
- indication lamps
- Pushbuttons close-open

Specifications to be indicated for circuit-breaker VA-2/VAS-2:
Short-circuit capacity, rated current, rated voltage and capacity to be secured

(*) Available voltages: 24 V AC/DC, 48 V AC/DC, 110 V AC/DC, 230 V AC

DF-AAD ESW

Protection cubicle with double interruption, integrated protection relay and earthing switch.

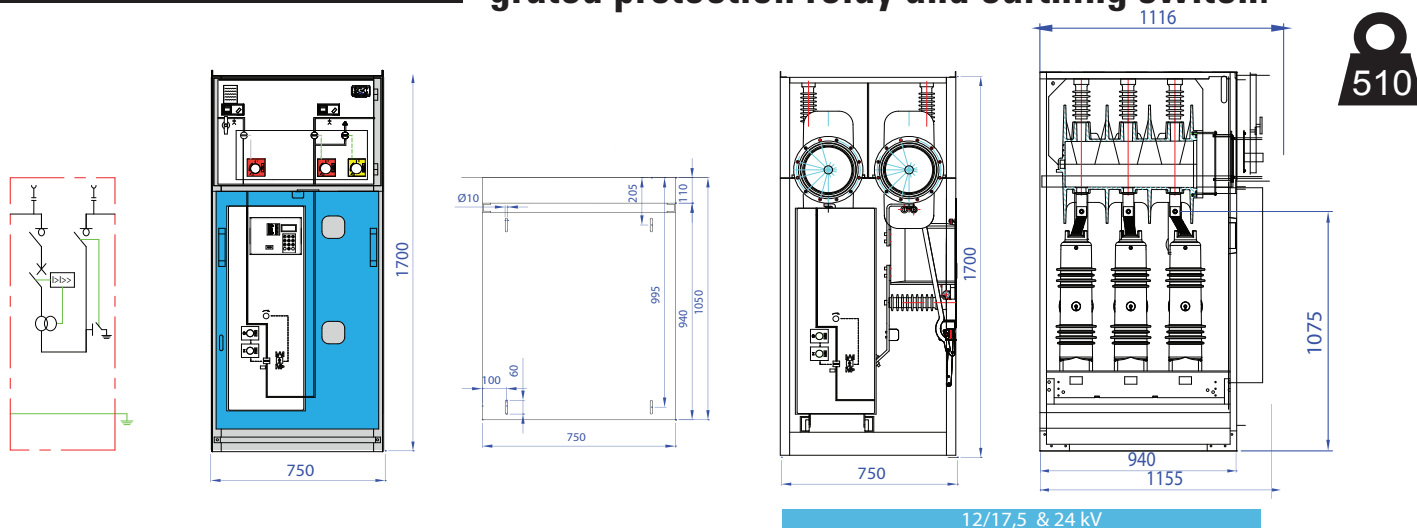

Standard Equipment

- Triple-phase load break switch RV44, class E3 according to IEC 62271-103, SF₆-insulation
- Vacuum circuit breaker without integrated protection relay
- Door interlock
- Low voltage compartment
- Insulators with capacitive device for VDS (Voltage Detection System)
- Holder for capacitive voltage indicators load break switch 1 and/or 2
- Floor panels

Cubicle Options

- Set of auxiliary contacts on load break switch 1 and/or 2
- Key interlock on load break switch 1 and/or 2
- Key interlock on earthing switch
- Mechanical interlock between the load break switches
- No door interlock
- Motor operation on load break switch 1 and/or 2: 24-48-110 V AC/DC & 220 V AC
- Earthing connections on load break switch 1 and/or 2
- Earthing connections outside of cubicle
- Capacitive voltage indicators load break switch 1 and/or 2
- Cubicle base: 200 mm, 300 mm or 400 mm height (other dimensions on demand)
- Button press control on load break switch 1 and/or 2
- Remote control on load break switch 1 and/or 2
- Current transformers

APPLICATION

Protection of descending feeders with transformer and MV-equipment provided with circuit breaker and double separation of busbar upstream and downstream.

SPECIFICATIONS & DIMENSIONS

Rated Voltage	kV	12	17,5	24
Rated current	A	800/1250	800/1250	630/800
Short-term current	kA	25	25	20
Time of the short duration of current	s	1	1	1
Width	mm	750	750	750
Depth	mm	1050	1050	1050
Height	mm	1700	1700	1700
Weight	kg	510	510	510

Options on the circuit breaker

- Motor operation (*)
- Closing release
- Shunt trip 1-2 (*)
- Delayed/ direct Under voltage release (*)
- Set of auxiliary contacts from 1-6
- Fault contact on the relay
- Supply for test protective relay (battery block)
- Automatic recloser
- Remote control on circuit breaker
- Key interlock with load break switch and with earthing switch
- indication lamps
- Pushbuttons close-open

Specifications to be indicated for circuit-breaker VA-2/VAS-2: Short-circuit capacity, rated current, rated voltage and capacity to be secured

(*) Available voltages: 24 V AC/DC, 48 V AC/DC, 110 V AC/DC, 230 V AC

DF-AAD+

Protection cubicle with double interruption, integrated protection relay, arc-killer and gas exhaust duct.

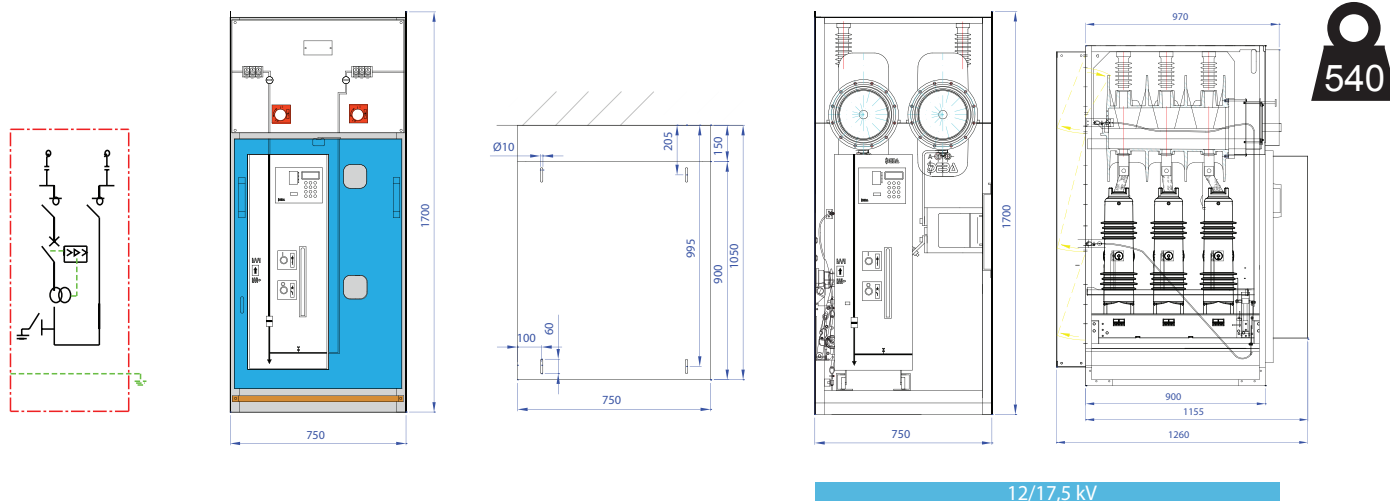

Standard Equipment

- Triple-phase load break switch RV44, class E3 according to IEC 62271-103, SF₆-insulation
- Vacuum circuit breaker with integrated protection relay
- Door interlock
- Low voltage compartment
- Insulators with capacitive device for VDS (Voltage Detection System)
- Holder for capacitive voltage indicators load break switch 1 and/or 2
- Arc-killer SV-25 inside
- Gas exhaust duct at the rear of the cubicle
- Floor panels

Cubicle Options

- Set of auxiliary contacts on load break switch 1 and/or 2
- Key interlock on load break switch 1 and/or 2
- Key interlock on earthing switch
- Mechanical interlock between the load break switches
- No door interlock
- Motor operation on load break switch 1 and/or 2: 24-48-110 V AC/DC & 220 V AC
- Earthing switch
- Earthing connections on load break switch 1 and/or 2
- Earthing connections outside of cubicle
- Capacitive voltage indicators load break switch 1 and/or 2
- Cubicle base: 200 mm, 300 mm or 400 mm height (other dimensions on demand)
- Button press control on load break switch 1 and/or 2
- Remote control on load break switch 1 and/or 2
- Current transformers

APPLICATION

Protection of descending feeders with transformer and MV-equipment provided with circuit breaker and double separation of busbar upstream and downstream.

SPECIFICATIONS & DIMENSIONS

Rated Voltage	kV	12	17,5
Rated current	A	800/1250	800/1250
Short-term current	kA	25	25
Time of the short duration of current	s	1	1
Width	mm	750	750
Depth	mm	1050	1050
Height	mm	1700	1700
Weight	kg	540	540

Options on the circuit breaker

- Motor operation (*)
- Closing release
- Shunt trip 1-2 (*)
- Delayed/ direct Under voltage release (*)
- Set of auxiliary contacts from 1-6
- Fault contact on the relay
- Supply for test protective relay (battery block)
- Automatic recloser
- Remote control on circuit breaker
- Key interlock with load break switch and with earthing switch
- indication lamps
- Pushbuttons close-open

Specifications to be indicated for circuit-breaker VA-2/VAS-2:
Short-circuit capacity, rated current, rated voltage and capacity to be secured

(*) Available voltages: 24 V AC/DC, 48 V AC/DC, 110 V AC/DC, 230 V AC

DF-AAD+ ESW

Protection cubicle with double interruption, integrated protection relay, arc-killer, gas exhaust duct and earthing switch.

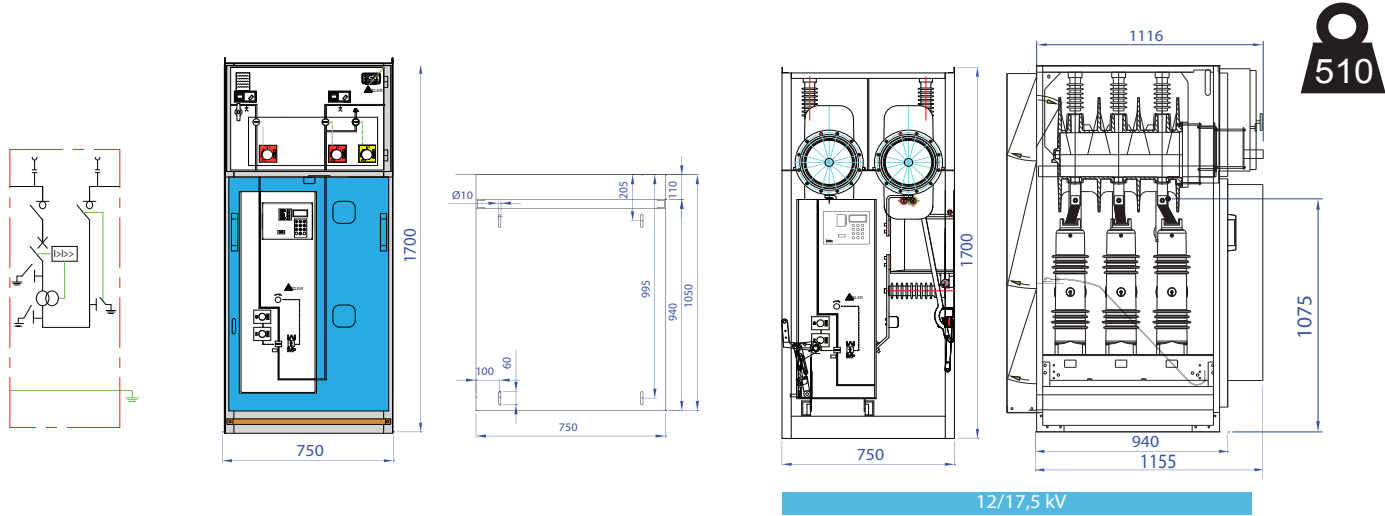

Standard Equipment

- Triple-phase load break switch RV44, class E3 according to IEC 62271-103, SF₆-insulation
- Vacuum circuit breaker with integrated protection relay
- Door interlock
- Low voltage compartment
- Insulators with capacitive device for VDS (Voltage Detection System)
- Holder for capacitive voltage indicators load break switch 1 and/or 2
- Arc-killer SV-25 inside
- Gas exhaust duct at the rear of the cubicle
- Floor panels
- Earthing switch

Cubicle Options

- Set of auxiliary contacts on load break switch 1 and/or 2
- Key interlock on load break switch 1 and/or 2
- Key interlock on earthing switch
- Mechanical interlock between the load break switches
- No door interlock
- Motor operation on load break switch 1 and/or 2: 24-48-110 V AC/DC & 220 V AC
- Earthing connections on load break switch 1 and/or 2
- Earthing connections outside of cubicle
- Capacitive voltage indicators load break switch 1 and/or 2
- Cubicle base: 200 mm, 300 mm or 400 mm height (other dimensions on demand)
- Button press control on load break switch 1 and/or 2
- Remote control on load break switch 1 and/or 2
- Current transformers

APPLICATION

Protection of descending feeders with transformer and MV-equipment provided with circuit breaker and double separation of busbar upstream and downstream.

SPECIFICATIONS & DIMENSIONS

Rated Voltage	kV	12	17,5
Rated current	A	800/1250	800/1250
Short-term current	kA	25	25
Time of the short duration of current	s	1	1
Width	mm	750	750
Depth	mm	1050	1050
Height	mm	1700	1700
Weight	kg	540	540

Options on the circuit breaker

- Motor operation (*)
- Closing release
- Shunt trip 1-2 (*)
- Delayed/ direct Under voltage release (*)
- Set of auxiliary contacts from 1-6
- Fault contact on the relay
- Supply for test protective relay (battery block)
- Automatic recloser
- Remote control on circuit breaker
- Key interlock with load break switch and with earthing switch
- indication lamps
- Pushbuttons close-open

Specifications to be indicated for circuit-breaker VA-2/VAS-2: Short-circuit capacity, rated current, rated voltage and capacity to be secured

(*) Available voltages: 24 V AC/DC, 48 V AC/DC, 110 V AC/DC, 230 V AC

DF-AAD/EDN

Protection cubicle with double interruption and protection relay in low voltage compartment.

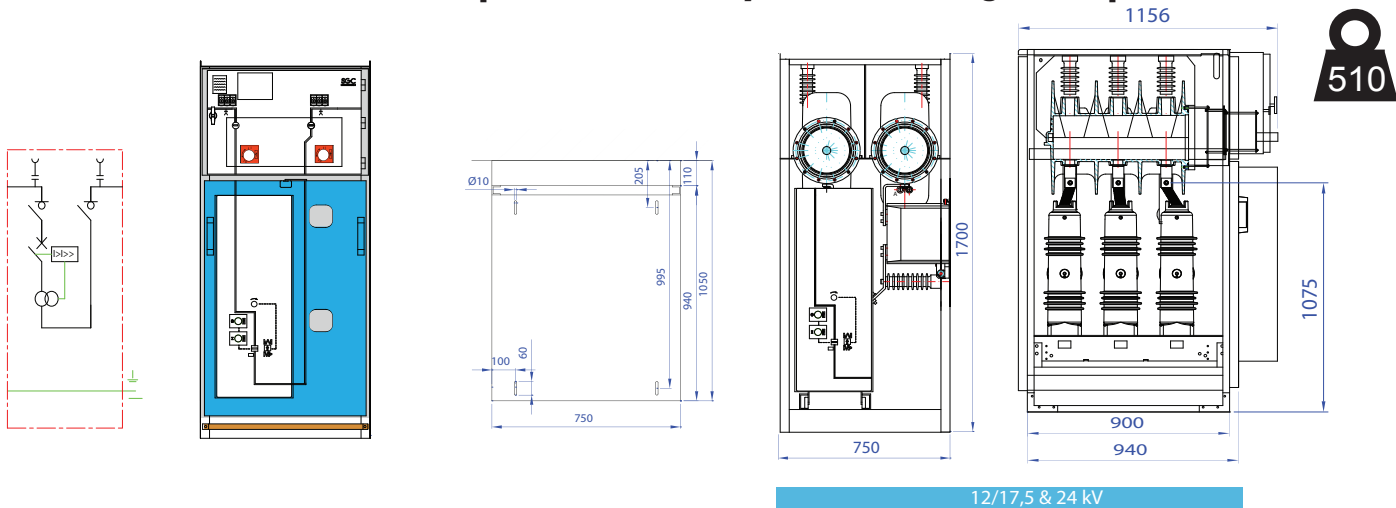

Standard Equipment

- Triple-phase load break switch RV44, class E3 according to IEC 62271-103, SF₆-insulation
- Vacuum circuit breaker
- Door interlock
- Protection relay in low voltage compartment
- Insulators with capacitive device for VDS (Voltage Detection System)
- Holder for capacitive voltage indicators load break switch 1 and/or 2
- Floor panels

Cubicle Options

- Set of auxiliary contacts on load break switch 1 and/or 2
- Key interlock on load break switch 1 and/or 2
- Key interlock on earthing switch
- Mechanical interlock between the load break switches
- No door interlock
- Motor operation on load break switch 1 and/or 2: 24-48-110 V AC/DC & 220 V AC
- Earthing-switch
- Earthing connections on load break switch 1 and/or 2
- Earthing connections outside of cubicle
- Capacitive voltage indicators load break switch 1 and/or 2
- Cubicle base: 200 mm, 300 mm or 400 mm height (other dimensions on demand)
- Button press control on load break switch 1 and/or 2
- Remote control on load break switch 1 and/or 2
- Current transformers

APPLICATION

Protection of descending feeders with transformer and MV-equipment provided with circuit breaker and double separation of busbar upstream and downstream.

SPECIFICATIONS & DIMENSIONS

Rated Voltage	kV	12	17,5	24
Rated current	A	800/1250	800/1250	630/800
Short-term current	kA	25	25	20
Time of the short duration of current	s	1	1	1
Width	mm	750	750	750
Depth	mm	1050	1050	1050
Height	mm	1700	1700	1700
Weight	kg	510	510	510

Options on the circuit breaker

- Motor operation (*)
- Closing release
- Shunt trip 1-2 (*)
- Delayed/ direct Under voltage release (*)
- Set of auxiliary contacts from 1-6
- Fault contact on the relay
- Supply for test protective relay (battery block)
- Automatic recloser
- Remote control on circuit breaker
- Key interlock with load break switch and with earthing switch
- Indication lamps
- Pushbuttons close-open

Specifications to be indicated for circuit-breaker VA-2/VAS-2:
Short-circuit capacity, rated current, rated voltage and capacity to be secured

(*) Available voltages: 24 V AC/DC, 48 V AC/DC, 110 V AC/DC, 230 V AC

DF-AAD+/EDN

Protection cubicle with double interruption, protection relay in low voltage compartment, arc-killer and gas exhaust duct.

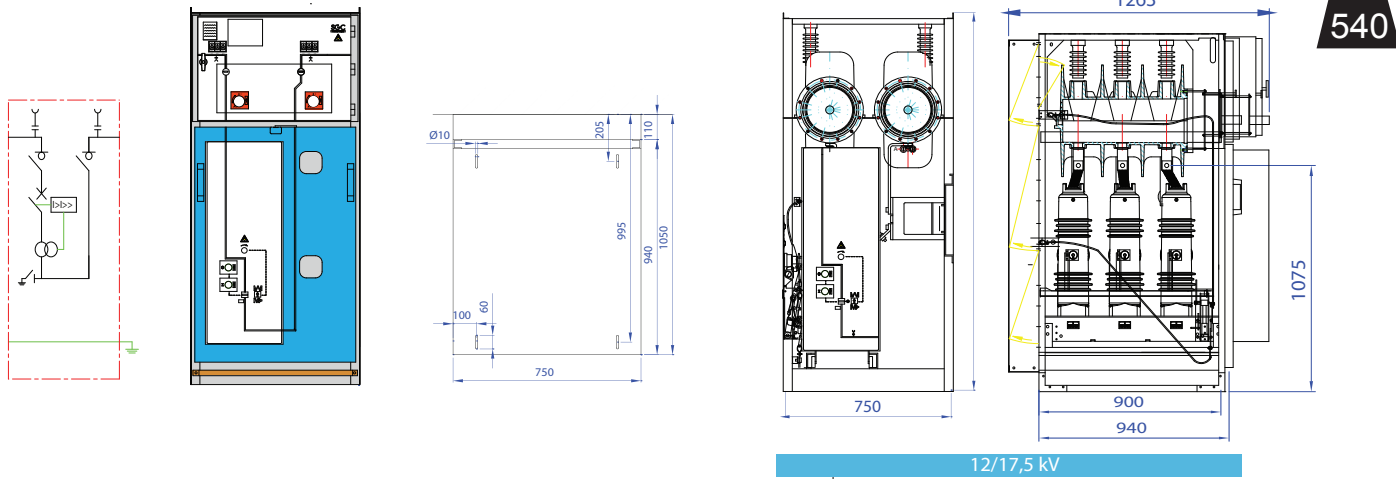

Standard Equipment

- Triple-phase load break switch RV44, class E3 according to IEC 62271-103, SF₆-insulation
- Vacuum circuit breaker
- Door interlock
- Protection relay in low voltage compartment
- Insulators with capacitive device for VDS (Voltage Detection System)
- Holder for capacitive voltage indicators load break switch 1 and/or 2
- Arc-killer SV-25 inside
- Gas exhaust duct at the rear of the cubicle
- Floor panels

Cubicle Options

- Set of auxiliary contacts on load break switch 1 and/or 2
- Key interlock on load break switch 1 and/or 2
- Key interlock on earthing switch
- Mechanical interlock between the load break switches
- No door interlock
- Motor operation on load break switch 1 and/or 2: 24-48-110 V AC/DC & 220 V AC
- Earthing-switch
- Earthing connections on load break switch 1 and/or 2
- Earthing connections outside of cubicle
- Capacitive voltage indicators load break switch 1 and/or 2
- Cubicle base: 200 mm, 300 mm or 400 mm height (other dimensions on demand)
- Button press control on load break switch 1 and/or 2
- Remote control on load break switch 1 and/or 2
- Current transformers

APPLICATION

Protection of descending feeders with transformer and MV-equipment provided with circuit breaker and double separation of busbar upstream and downstream.

SPECIFICATIONS & DIMENSIONS

Rated Voltage	kV	12	17,5
Rated current	A	800/1250	800/1250
Short-term current	kA	25	25
Time of the short duration of current	s	1	1
Width	mm	750	750
Depth	mm	1050	1050
Height	mm	1700	1700
Weight	kg	540	540

Options on the circuit breaker

- Motor operation (*)
- Closing release
- Shunt trip 1-2 (*)
- Delayed/ direct Under voltage release (*)
- Set of auxiliary contacts from 1-6
- Fault contact on the relay
- Supply for test protective relay (battery block)
- Automatic recloser
- Remote control on circuit breaker
- Key interlock with load break switch and with earthing switch
- indication lamps
- Pushbuttons close-open

Specifications to be indicated for circuit-breaker VA-2/VAS-2:
Short-circuit capacity, rated current, rated voltage and capacity to be secured

(*) Available voltages: 24 V AC/DC, 48 V AC/DC, 110 V AC/DC, 230 V AC

DF-AAD/EDN + ESW

Protection cubicle with double interruption,
protection relay in low voltage compartment and
earthing switch.

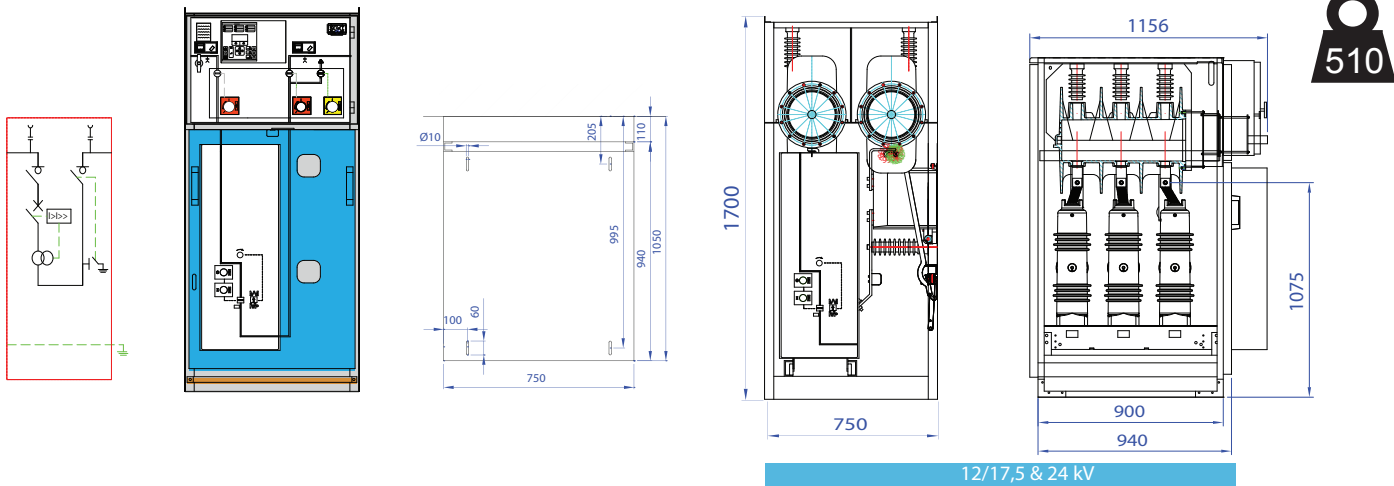

Standard Equipment

- Triple-phase load break switch RV44, class E3 according to IEC 62271-103, SF₆-insulation
- Vacuum circuit breaker
- Door interlock
- Protection relay in low voltage compartment
- Insulators with capacitive device for VDS (Voltage Detection System)
- Holder for capacitive voltage indicators load break switch 1 and/or 2
- Floor panels
- Earthing switch

Cubicle Options

- Set of auxiliary contacts on load break switch 1 and/or 2
- Key interlock on load break switch 1 and/or 2
- Key interlock on earthing switch
- Mechanical interlock between the load break switches
- No door interlock
- Motor operation on load break switch 1 and/or 2: 24-48-110 V AC/DC & 220 V AC
- Earthing connections on load break switch 1 and/or 2
- Earthing connections outside of cubicle
- Capacitive voltage indicators load break switch 1 and/or 2
- Cubicle base: 200 mm, 300 mm or 400 mm height (other dimensions on demand)
- Button press control on load break switch 1 and/or 2
- Remote control on load break switch 1 and/or 2
- Current transformers

APPLICATION

Protection of descending feeders with transformer and MV-equipment provided with circuit breaker and double separation of busbar upstream and downstream.

SPECIFICATIONS & DIMENSIONS

Rated Voltage	kV	12	17,5	24
Rated current	A	800/1250	800/1250	630/800
Short-term current	kA	25	25	20
Time of the short duration of current	s	1	1	1
Width	mm	750	750	750
Depth	mm	1050	1050	1050
Height	mm	1700	1700	1700
Weight	kg	510	510	510

Options on the circuit breaker

- Motor operation (*)
- Closing release
- Shunt trip 1-2 (*)
- Delayed/ direct Under voltage release (*)
- Set of auxiliary contacts from 1-6
- Fault contact on the relay
- Supply for test protective relay (battery block)
- Automatic recloser
- Remote control on circuit breaker
- Key interlock with load break switch and with earthing switch
- indication lamps
- Pushbuttons close-open

Specifications to be indicated for circuit-breaker VA-2/VAS-2:
Short-circuit capacity, rated current, rated voltage and capacity to be secured

(*) Available voltages: 24 V AC/DC, 48 V AC/DC, 110 V AC/DC, 230 V AC

DF-AAD+/EDN +ESW

Protection cubicle with double interruption, protection relay in low voltage compartment, arc-killer, gas exhaust duct and earthing switch.

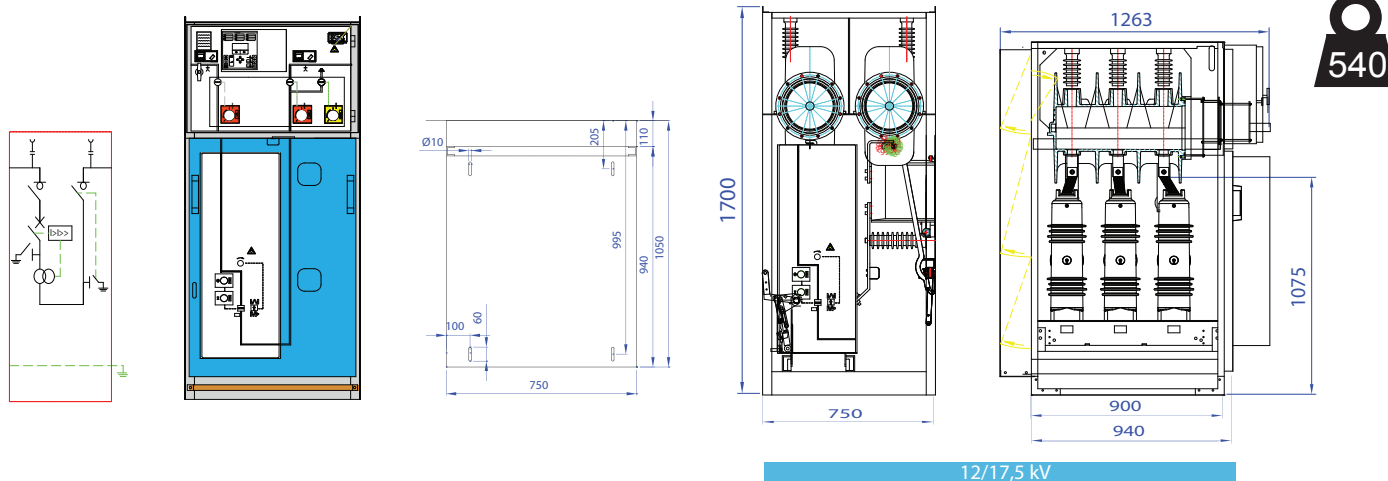

Standard Equipment

- Triple-phase load break switch RV44, class E3 according to IEC 62271-103, SF₆-insulation
- Vacuum circuit breaker
- Door interlock
- Protection relay in low voltage compartment
- Insulators with capacitive device for VDS (Voltage Detection System)
- Holder for capacitive voltage indicators load break switch 1 and/or 2
- Arc-killer SV-25 inside
- Gas exhaust duct at the rear of the cubicle
- Floor panels
- Earthing switch

Cubicle Options

- Set of auxiliary contacts on load break switch 1 and/or 2
- Key interlock on load break switch 1 and/or 2
- Key interlock on earthing switch
- Mechanical interlock between the load break switches
- No door interlock
- Motor operation on load break switch 1 and/or 2: 24-48-110 V AC/DC & 220 V AC
- Earthing connections on load break switch 1 and/or 2
- Earthing connections outside of cubicle
- Capacitive voltage indicators load break switch 1 and/or 2
- Cubicle base: 200 mm, 300 mm or 400 mm height (other dimensions on demand)
- Button press control on load break switch 1 and/or 2
- Remote control on load break switch 1 and/or 2
- Current transformers

APPLICATION

Protection of descending feeders with transformer and MV-equipment provided with circuit breaker and double separation of busbar upstream and downstream.

SPECIFICATIONS & DIMENSIONS

Rated Voltage	kV	12	17,5
Rated current	A	800/1250	800/1250
Short-term current	kA	25	25
Time of the short duration of current	s	1	1
Width	mm	750	750
Depth	mm	1050	1050
Height	mm	1700	1700
Weight	kg	540	540

Options on the circuit breaker

- Motor operation (*)
- Closing release
- Shunt trip 1-2 (*)
- Delayed/ direct Under voltage release (*)
- Set of auxiliary contacts from 1-6
- Fault contact on the relay
- Supply for test protective relay (battery block)
- Automatic recloser
- Remote control on circuit breaker
- Key interlock with load break switch and with earthing switch
- Indication lamps
- Pushbuttons close-open

Specifications to be indicated for circuit-breaker VA-2/VAS-2:
Short-circuit capacity, rated current, rated voltage and capacity to be secured

(*) Available voltages: 24 V AC/DC, 48 V AC/DC, 110 V AC/DC, 230 V AC

DF-AADT

Protection cubicle with double interruption and vacuum circuit breaker (magnetic driven).

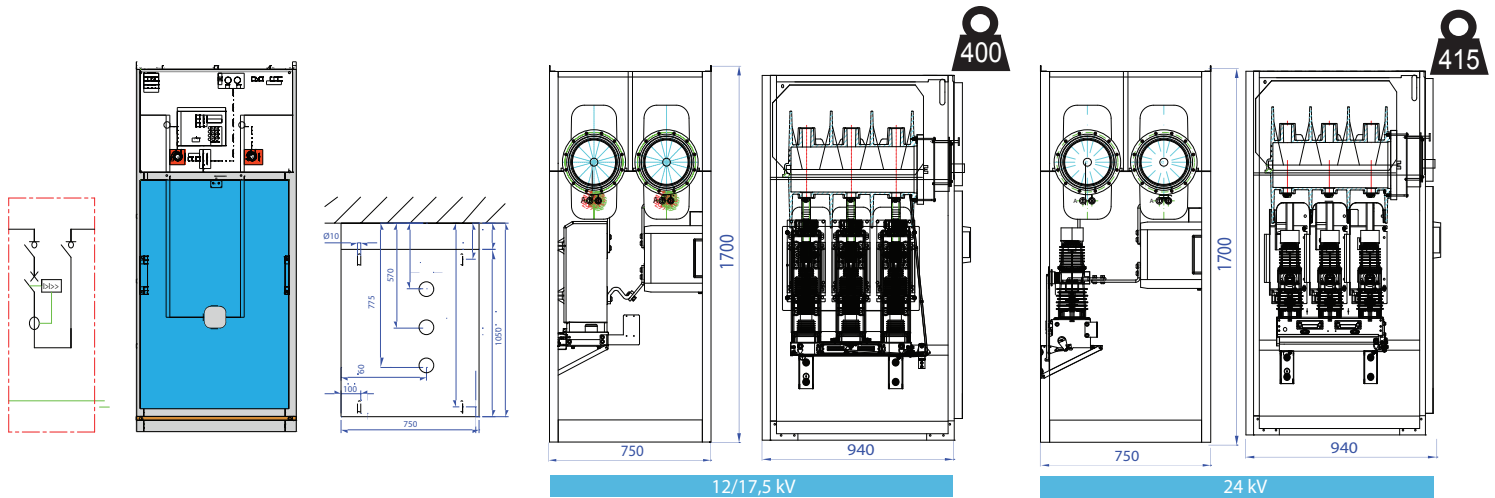

Standard Equipment

- Double, triple-phase load break switch RV44 - class E3 according to IEC 62271-103, SF₆ insulation
- Vacuum circuit breaker with magnetic drive
- Cable support structure
- Door interlock
- Insulators with capacitive device for VDS (Voltage Detection System)
- Voltage presence indicators
- LV compartment
- Floor panels

Cubicle Options

- Auxiliary contacts on load break switch 1 and/or 2 up to 3NO/NC
- Auxiliary contacts on the earthing switch up to 2NO/NC
- Key interlock on the load break switch
- Key interlock on the earthing switch
- Key interlock on both
- No door interlock
- Choice of auxiliary voltage: 24-60-110 VDC or 110-220 VAC
- Short circuit indicator (to be specified by the customer)
- Current transformers (to be specified by the customer)
- Earthing connection upstream from the circuit breaker
- Voltage indication
- Cubicle base: 200, 300, 400 mm height (other dimensions on demand)
- Button press control on the load break switch
- Remote control on the load break switch

APPLICATION

Protection of descending feeders with transformer and MV-equipment provided with circuit breaker and double separation of the bus-bar upstream and downstream.

SPECIFICATIONS & DIMENSIONS

Rated Voltage	kV	12	17,5	24
Rated current	A	800/1250	800/1250	630/800
Short-term current	kA	16/20/25	16/20/25	16
Time of the short duration of current	s	1/2/3	1/2/3	1/2/3
Width	mm	750	750	750
Depth	mm	940	940	940
Height	mm	1700	1700	1700
Weight	kg	400	400	415

Options on the circuit breaker

- Under-voltage release (electronic)
- Block auxiliary contacts
- Operation counter
- Reclosing function (standard)
- Remote control
- Interlock

Specifications to be indicated for circuit-breaker:
Short-circuit capacity, rated current, rated voltage and capacity to be secured

DF-AADT +vt

Protection cubicle with double interruption, circuit breaker (magnetic driven) and voltage transformer.

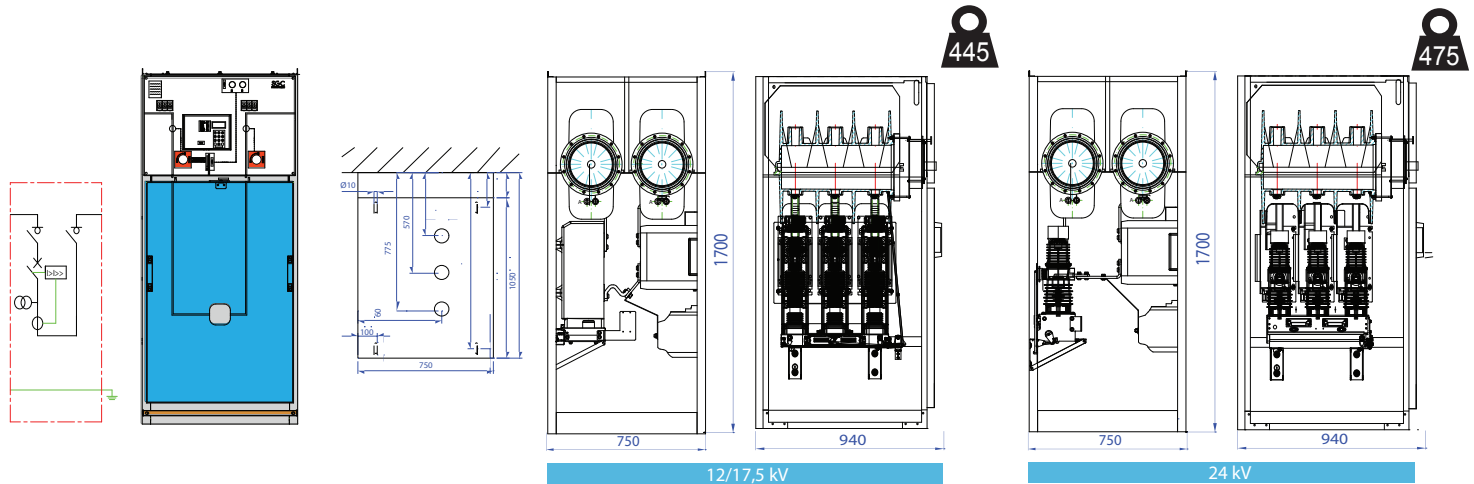

Standard Equipment

- Double, triple-phase load break switch RV44 - class E3 according to IEC 62271-103, SF₆ insulation
- Vacuum circuit breaker with magnetic drive
- Cable support structure
- Door interlock
- Insulators with capacitive device for VDS (Voltage Detection System)
- Voltage presence indicators
- LV compartment
- Floor panels

Cubicle Options

- Auxiliary contacts on load break switch 1 and/or 2 up to 3NO/NC
- Auxiliary contacts on the earthing switch up to 2NO/NC
- Key interlock on the load break switch
- Key interlock on the earthing switch
- Key interlock on both
- No door interlock
- Choice of auxiliary voltage: 24-60-110 VDC or 110-220 VAC
- Short circuit indicator (to be specified by the customer)
- Current transformers (to be specified by the customer)
- Earthing connection upstream from the circuit breaker
- Voltage indication
- Cubicle base: 200, 300, 400 mm height (other dimensions on demand)
- Button press control on the load break switch
- Remote control on the load break switch

APPLICATION

Protection of descending feeders with transformer and MV-equipment provided with circuit breaker and double separation of the busbar upstream and downstream.

SPECIFICATIONS & DIMENSIONS

Rated Voltage	kV	12	17,5	24
Rated current	A	800/1250	800/1250	630/800
Short-term current	kA	16/20/25	16/20/25	16
Time of the short duration of current	s	1/2/3	1/2/3	1/2/3
Width	mm	750	750	750
Depth	mm	940	940	940
Height	mm	1700	1700	1700
Weight	kg	445	445	475

Options on the circuit breaker

- Under-voltage release (electronic)
- Block auxiliary contacts
- Operation counter
- Reclosing function (standard)
- Remote control
- Interlock

Specifications to be indicated for circuit-breaker:
Short-circuit capacity, rated current, rated voltage and capacity to be secured

DF-LK

Busbar coupling cubicle.

245

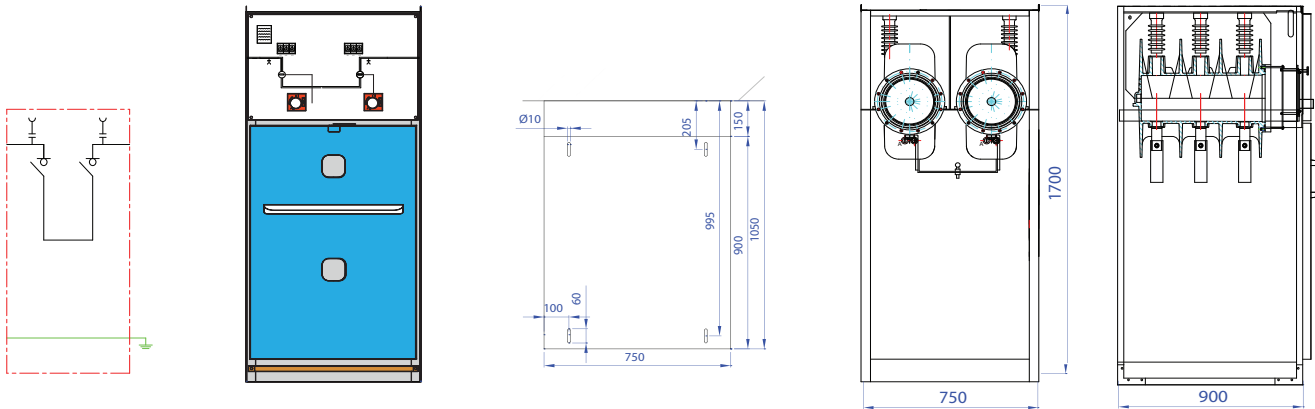

12/17,5 & 24 kV

Standard Equipment

- 2 triple-phase load break switch RV44, class E3 according to IEC 62271-103, SF₆-insulation
- Door interlock
- Low-voltage compartment
- Insulators with capacitive device for VDS (Voltage Detection System)
- Floor panels

Cubicle Options

- Holder for capacitive voltage indicators load break switch 1 and/or 2
- Set of auxiliary contacts on load break switch 1 and/or 2
- Key interlock on load break switch 1 and/or 2
- Key interlock on earthing switch
- Mechanical interlock between the load break switches
- No door interlock
- Motor operation on load break switch 1 and/or 2: 24-48-110 V AC/DC & 220 V AC
- Earthing switch
- Earthing connections on load break switch 1 and/or 2
- Earthing connections outside of cubicle
- Capacitive voltage indicators load break switch 1 and/or 2
- Cubicle base: 200 mm, 300 mm or 400 mm height (other dimensions on demand)
- Button press control on load break switch 1 and/or 2
- Remote control on load break switch 1 and/or 2
- Current transformers

APPLICATION

Coupling between two parts of the MV-panel.

SPECIFICATIONS & DIMENSIONS

Rated Voltage	kV	12	17,5	24
Rated current	A	800/1250	800/1250	630/800
Short-term current	kA	25	25	20
Time of the short duration of current	s	1	1	1
Width	mm	750	750	750
Depth	mm	1050	1050	1050
Height	mm	1700	1700	1700
Weight	kg	245	245	245

OTHER OPTIONS & DIMENSIONS?

Please consult us for options and dimensions other than those mentioned in this catalogue.

DF-LKK

Busbar coupling cubicle with cable.

245

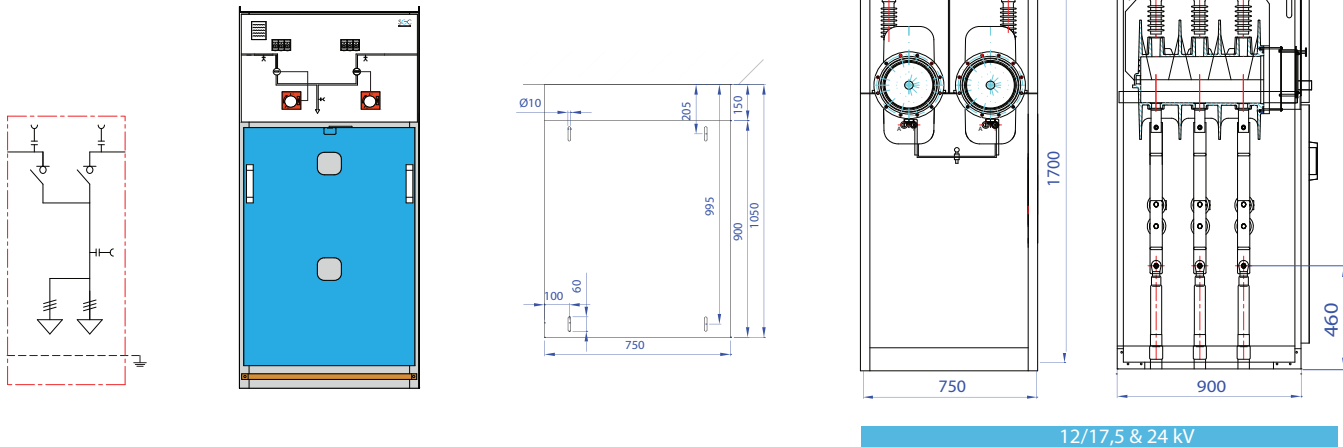

Standard Equipment

- 2 triple-phase load break switch RV44, class E3 according to IEC 62271-103, SF₆-insulation
- Door interlock
- Low-voltage compartment
- Insulators with capacitive device for VDS (Voltage Detection System)
- Floor panels

Cubicle Options

- Holder for capacitive voltage indicators load break switch 1 and/or 2
- Set of auxiliary contacts on load break switch 1 and/or 2
- Key interlock on load break switch 1 and/or 2
- Key interlock on earthing switch
- Mechanical interlock between the load break switches
- No door interlock
- Motor operation on load break switch 1 and/or 2: 24-48-110 V AC/DC & 220 V AC
- Earthing switch
- Earthing connections on load break switch 1 and/or 2
- Earthing connections outside of cubicle
- Capacitive voltage indicators load break switch 1 and/or 2
- Cubicle base: 200 mm, 300 mm or 400 mm height (other dimensions on demand)
- Button press control on load break switch 1 and/or 2
- Remote control on load break switch 1 and/or 2
- Current transformers

APPLICATION

Coupling between two parts of the MV-panel.

SPECIFICATIONS & DIMENSIONS

Rated Voltage	kV	12	17,5	24
Rated current	A	800/1250	800/1250	630/800
Short-term current	kA	25	25	20
Time of the short duration of current	s	1	1	1
Width	mm	750	750	750
Depth	mm	1050	1050	1050
Height	mm	1700	1700	1700
Weight	kg	245	245	245

OTHER OPTIONS & DIMENSIONS?

Please consult us for options and dimensions other than those mentioned in this catalogue.

DF-LKE

Busbar coupling cubicle with earthing switch.

245

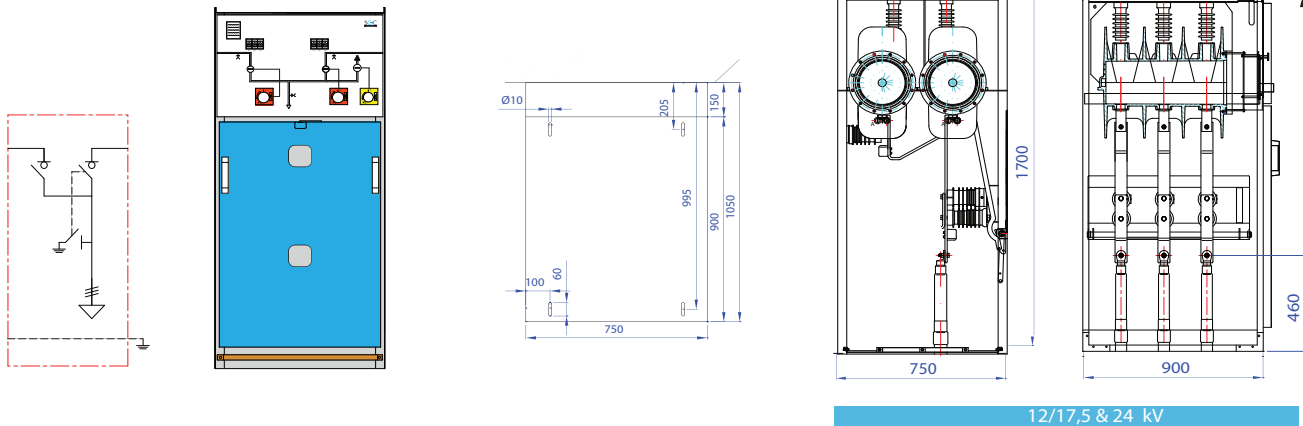

Standard Equipment

- 2 triple-phase load break switch RV44, class E3 according to IEC 62271-103, SF₆-insulation
- Door interlock
- Low-voltage compartment
- Insulators with capacitive device for VDS (Voltage Detection System)
- Floor panels

Cubicle Options

- Holder for capacitive voltage indicators load break switch 1 and/or 2
- Set of auxiliary contacts on load break switch 1 and/or 2
- Key interlock on load break switch 1 and/or 2
- Key interlock on earthing switch
- Mechanical interlock between the load break switches
- No door interlock
- Motor operation on load break switch 1 and/or 2: 24-48-110 V AC/DC & 220 V AC
- Earthing switch
- Earthing connections on load break switch 1 and/or 2
- Earthing connections outside of cubicle
- Capacitive voltage indicators load break switch 1 and/or 2
- Cubicle base: 200 mm, 300 mm or 400 mm height (other dimensions on demand)
- Button press control on load break switch 1 and/or 2
- Remote control on load break switch 1 and/or 2
- Current transformers

APPLICATION

Coupling between two parts of the MV-panel.

SPECIFICATIONS & DIMENSIONS

Rated Voltage	kV	12	17,5	24
Rated current	A	800/1250	800/1250	630/800
Short-term current	kA	25	25	20
Time of the short duration of current	s	1	1	1
Width	mm	750	750	750
Depth	mm	1050	1050	1050
Height	mm	1700	1700	1700
Weight	kg	245	245	245

OTHER OPTIONS & DIMENSIONS?

Please consult us for options and dimensions other than those mentioned in this catalogue.

DF-LKKE

Busbar coupling cubicle with cable and earthing switch.

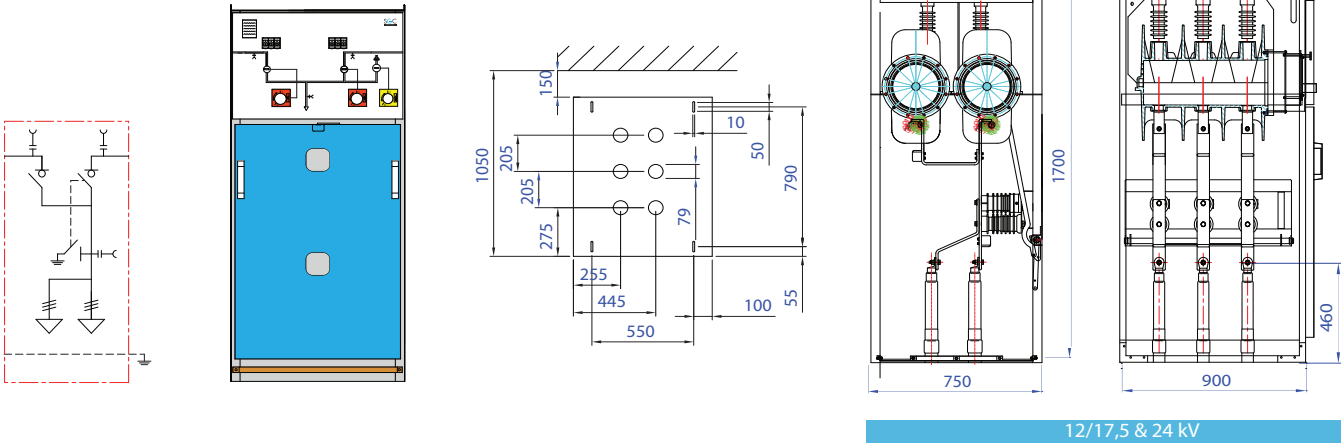

Standard Equipment

- 2 triple-phase load break switch RV44, class E3 according to IEC 62271-103, SF₆-insulation
- Door interlock
- Low-voltage compartment
- Insulators with capacitive device for VDS (Voltage Detection System)
- Floor panels

Cubicle Options

- Holder for capacitive voltage indicators load break switch 1 and/or 2
- Set of auxiliary contacts on load break switch 1 and/or 2
- Key interlock on load break switch 1 and/or 2
- Key interlock on earthing switch
- Mechanical interlock between the load break switches
- No door interlock
- Motor operation on load break switch 1 and/or 2: 24-48-110 V AC/DC & 220 V AC
- Earthing switch
- Earthing connections on load break switch 1 and/or 2
- Earthing connections outside of cubicle
- Capacitive voltage indicators load break switch 1 and/or 2
- Cubicle base: 200 mm, 300 mm or 400 mm height (other dimensions on demand)
- Button press control on load break switch 1 and/or 2
- Remote control on load break switch 1 and/or 2
- Current transformers

APPLICATION

Coupling between two parts of the MV-panel.

SPECIFICATIONS & DIMENSIONS

Rated Voltage	kV	12	17,5	24
Rated current	A	800/1250	800/1250	630/800
Short-term current	kA	25	25	20
Time of the short duration of current	s	1	1	1
Width	mm	750	750	750
Depth	mm	1050	1050	1050
Height	mm	1700	1700	1700
Weight	kg	245	245	245

OTHER OPTIONS & DIMENSIONS?

Please consult us for options and dimensions other than those mentioned in this catalogue.

DF-T

Transformer Housing

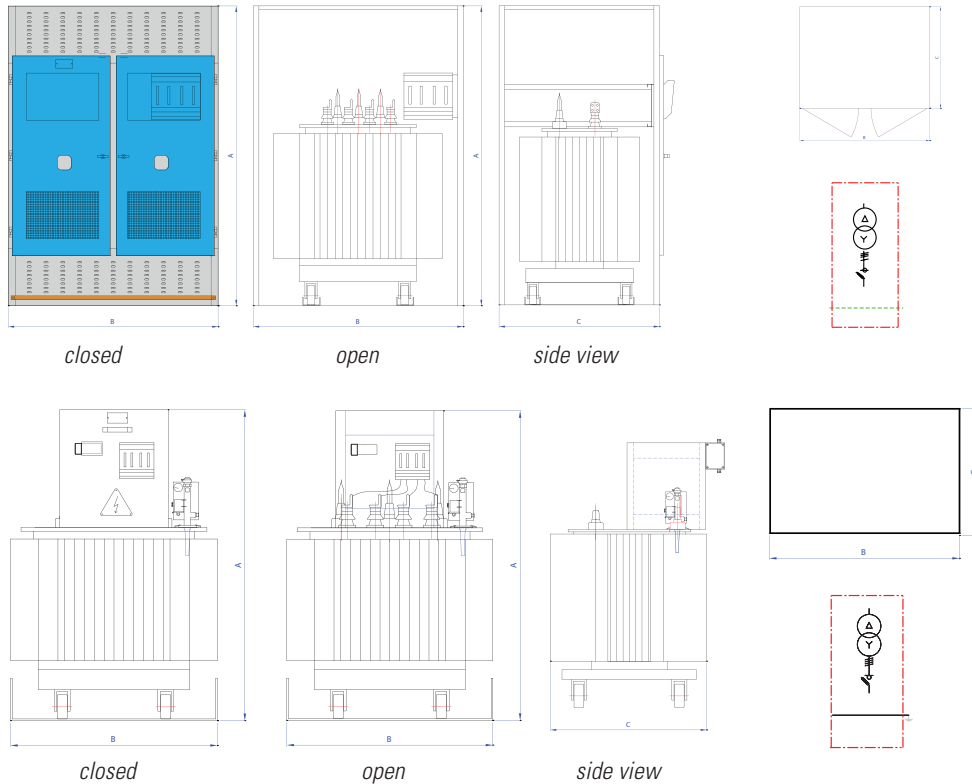

The DF-T was designed specifically with ventilation problems in mind. **The ventilation openings in the cubicle ensure that the transformer will constantly be ventilated.** The specific concept allows the transformer to be driven in and out smoothly at all times.

Standard Equipment

- Windows
- Ventilation openings
- Hinge door(s) in function of the cubicle width

Options

- Key interlock with LV protection
- Shaft with rail set on top of the transformer housing
- LV compartment
- Oil receptacle
- Forced ventilation
- With closed back
- With closed roof
- Extra ventilation
- Opening for LV switch of LV equipment
- Opening for the thermometer
- Opening for digital measuring set
- Holder for capacitive voltage indicators
- Capacitive voltage indicators
- IP 2X / IP 4X / IP 315
- Interlockable doors
- Interlock possibilities

If a built-in LV switch will be required in the DF-T, the size needs to be specified.

APPLICATION

The DF-T cubicle has been designed from the long-term practical experience of installing and connecting distribution transformers.

DIMENSIONS OIL FILLED TRANSFORMERS

	Width (B)	Height (A)	Depth (C)
100-160 kVA	1200	1900	1050
250-630 kVA	1400	2100	1150
800-1000 kVA	1800	2100	1150
1250-1600 kVA	2000	2100	1400
2000-2500 kVA	2400	2400	1500

DIMENSIONS CAST RESIN TRANSFORMERS

	Width (B)	Height (A)	Depth (C)
100-160 kVA	1500	1900	1050
250-630 kVA	1800	2100	1150
800-1000 kVA	2000	2100	1200
1250-1600 kVA	2200	2200	1300
2000-2500 kVA	2400	2400	1400

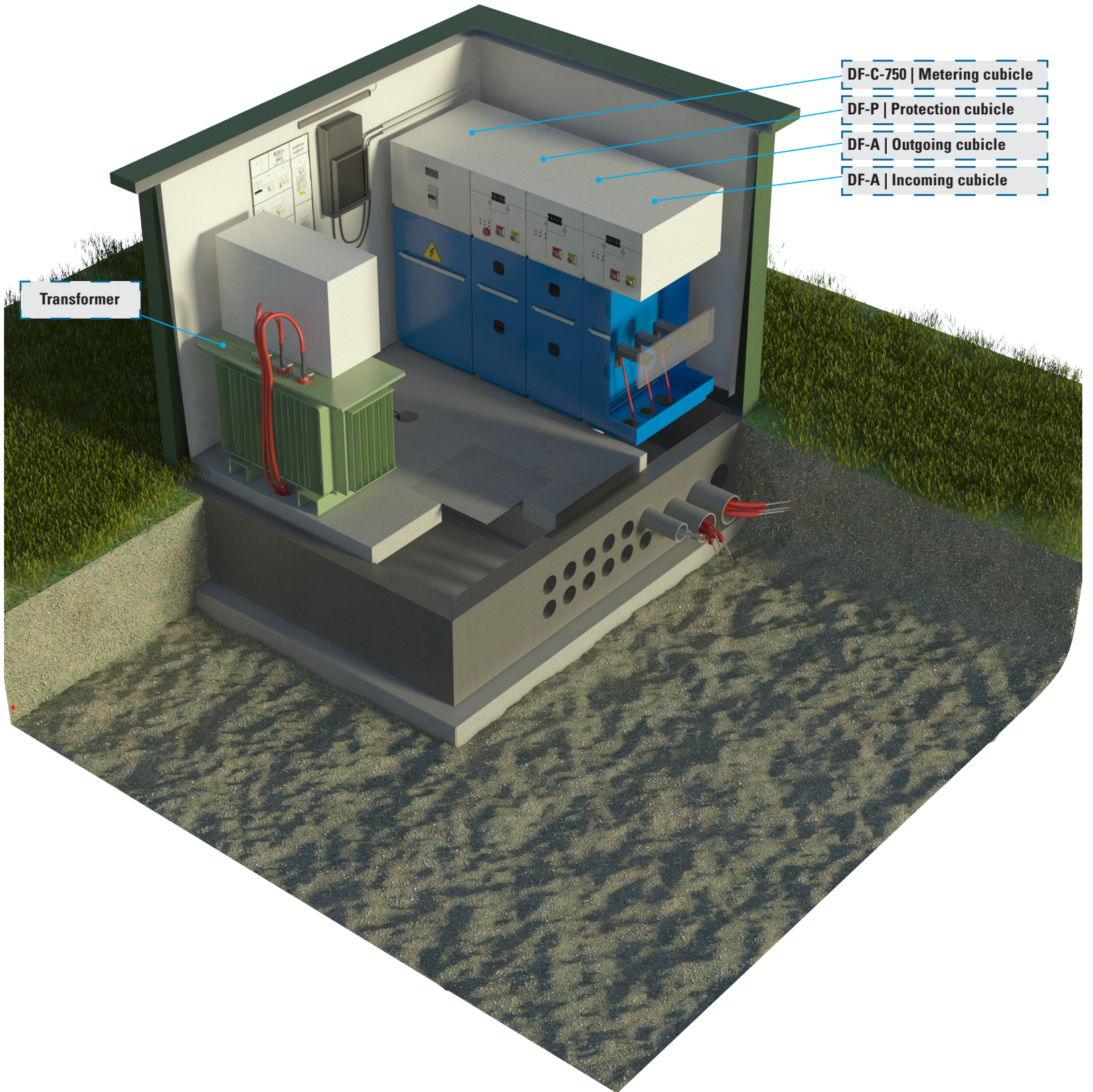

- DF-C-750 | Metering cubicle
- DF-P | Protection cubicle
- DF-A | Outgoing cubicle
- DF-A | Incoming cubicle

Transformer

DF-C-750

Metering cubicle type 1.

170

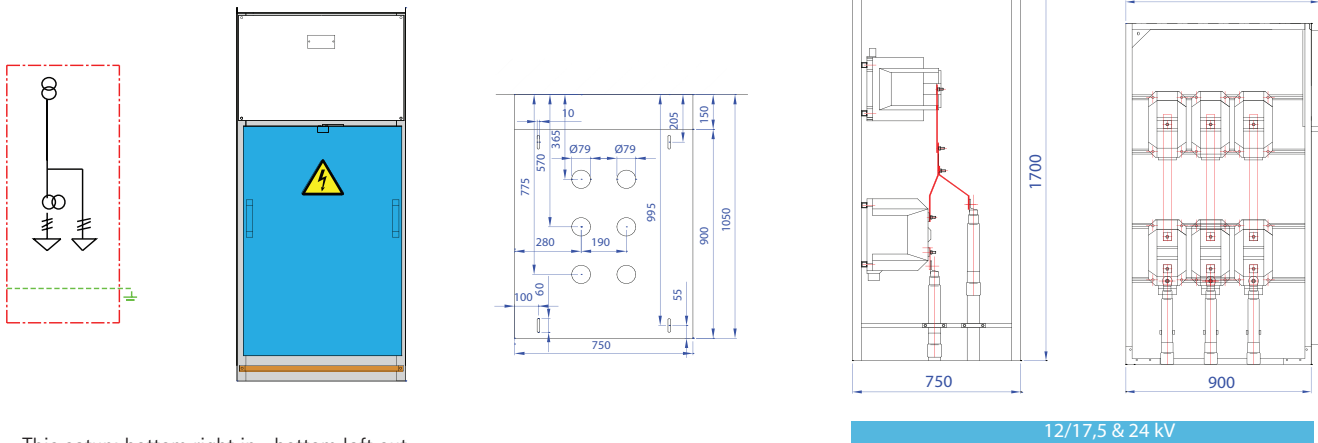

This setup: bottom right in - bottom left out

Standard Equipment

- 3 CT's xA => 5A
- 3 VT's xV => 110V, V3
- Floor panels
- Low voltage compartment safety box to secure voltage circuits
- Insulators with capacitive device for VDS (Voltage Detection System)

Options

- Additional current transformers
- Additional voltage transformer with or without MV and LV protection
- Support for the positioning of measuring transformers
- Measuring system with 3 CTs and 3 VTs
- Measuring system with kWh metering (requirements to be specified by the customer)
- Current measurement system
- Voltage measurement system
- Cubicle base: 200 mm, 300 mm or 400 mm high (Other dimensions on demand)
- Protection VT's with HRC-fuses

The following current transformer CT specifications will be specified by the customer:

Primary current, secondary current, capacity and precision class, insulation class, rated short time current

The following voltage transformer VT specifications will be specified by the customer:

Primary voltage, secondary voltage, capacity and precision class, insulation class

APPLICATION

The DF-C-750 cubicle has been designed for positioning current and voltage transformers to measure energy consumption.

SPECIFICATIONS & DIMENSIONS

Rated Voltage	kV	12	17,5	24
Rated current	A	up to 1250	up to 1250	up to 800
Short-term current	kA	25	25	20
Time of the short duration of current	s	1	1	1
Width	mm	750	750	750
Depth	mm	1050	1050	1050
Height	mm	1700	1700	1700
Weight (*)	kg	170	170	170

(*) Without equipment

OTHER OPTIONS & DIMENSIONS?

Please consult us for options and dimensions other than those mentioned in this catalogue.

Metering cubicle type 2.

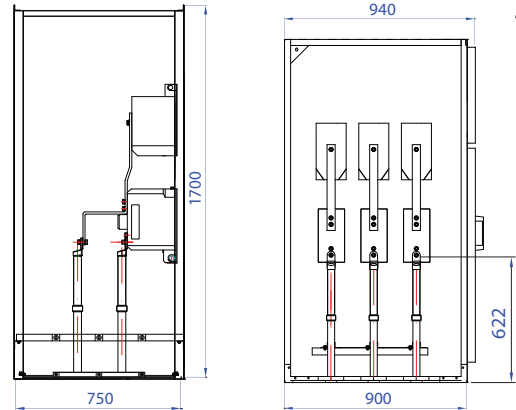
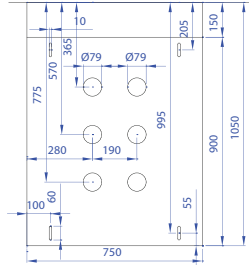
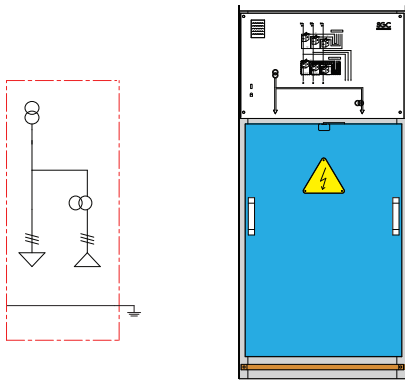

This setup: bottom left in - bottom right out

12/17,5 & 24 kV

Metering cubicle type 3.

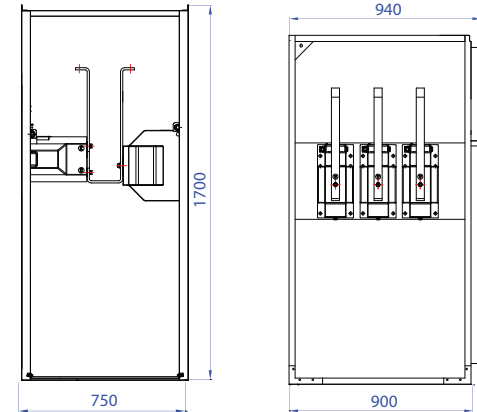
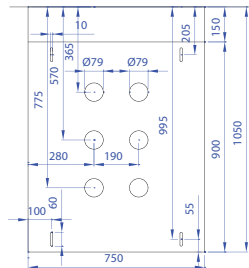
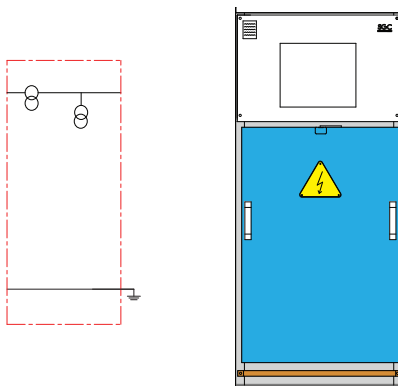

This setup: top left in - top right out

12/17,5 & 24 kV

Metering cubicle type 4.

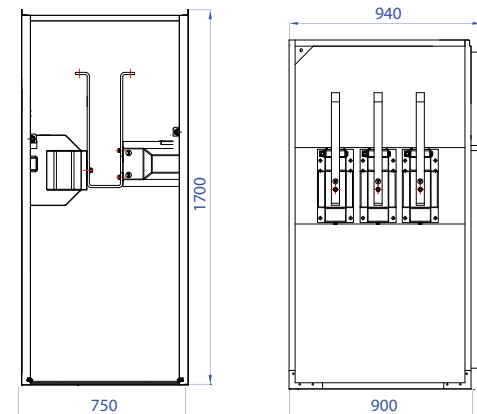
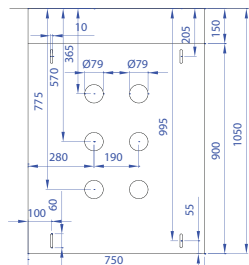
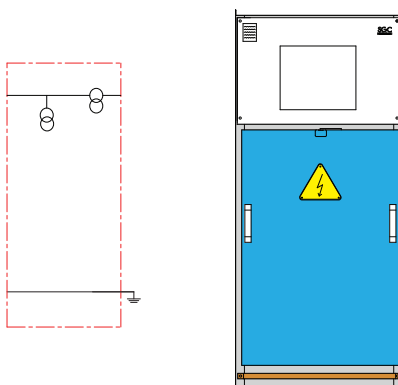

This setup: top right in - top left out

12/17,5 & 24 kV

DF-C-750

Metering cubicle type 5.

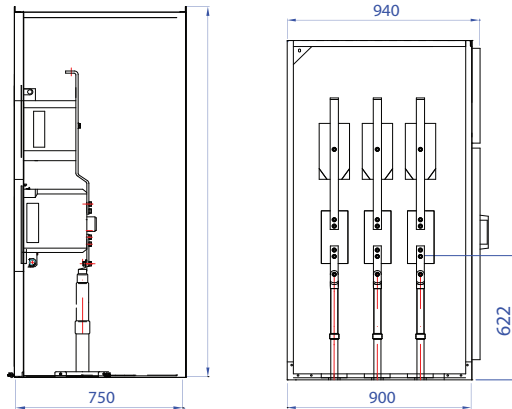
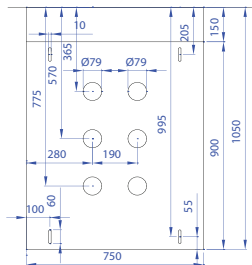
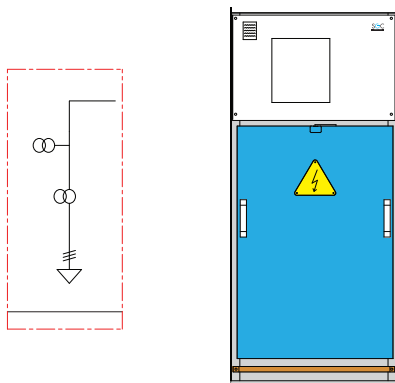

170

12/17,5 & 24 kV

This setup: bottom left in - top right out

Metering cubicle type 6.

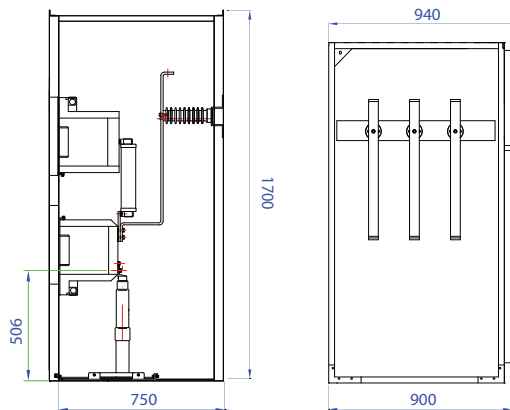
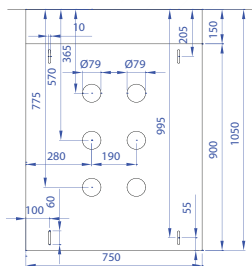
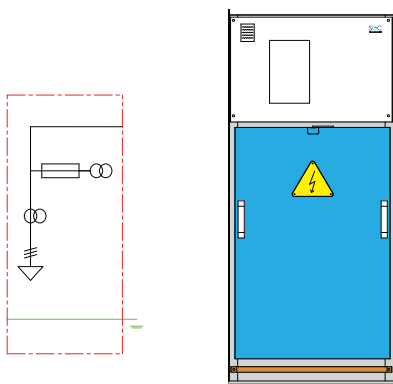

170

12/17,5 & 24 kV

This setup: bottom left in - top right out + fuse
(Note: also available bottom right in - top left out + fuse)

Metering cubicle type 7.

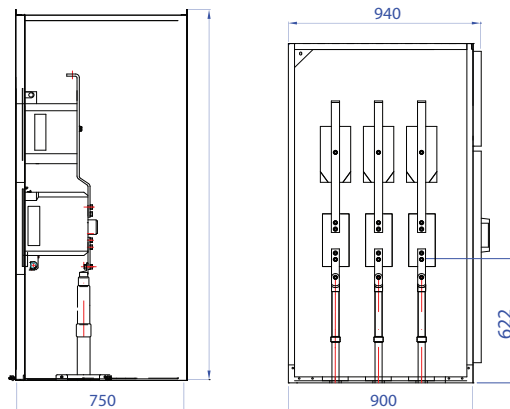
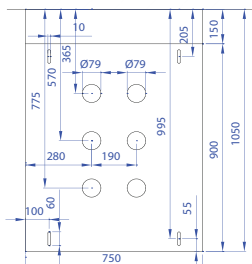
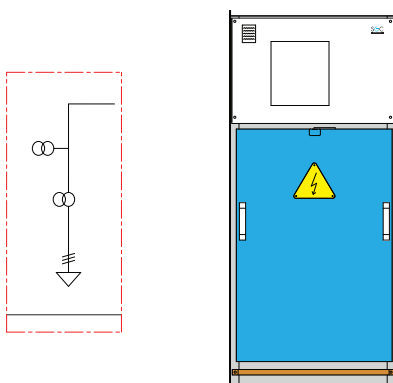

170

12/17,5 & 24 kV

This setup: bottom right in - top left out

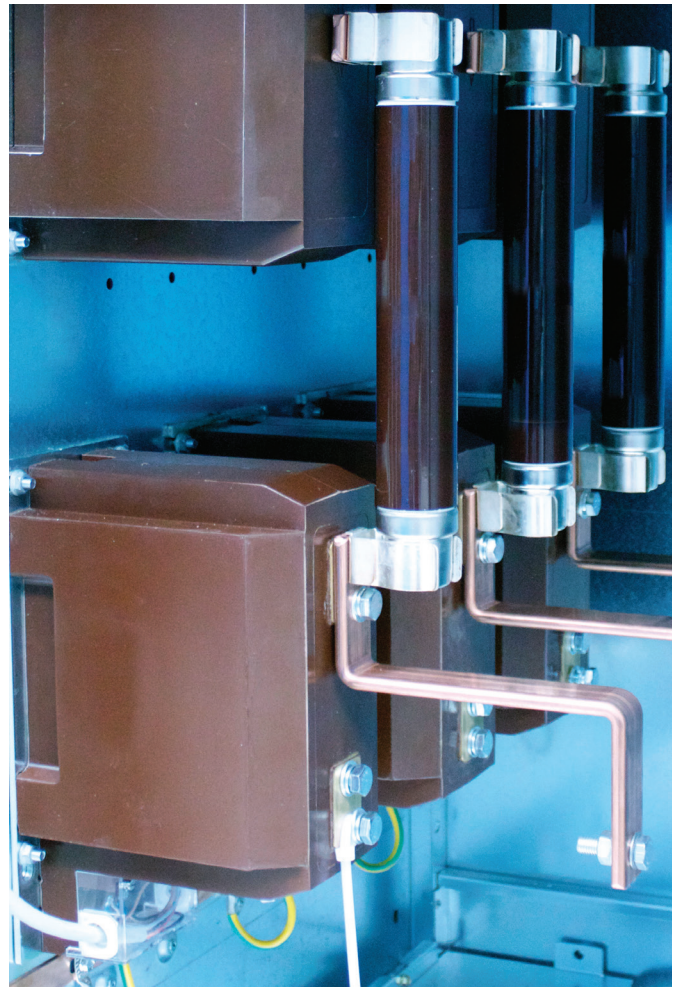
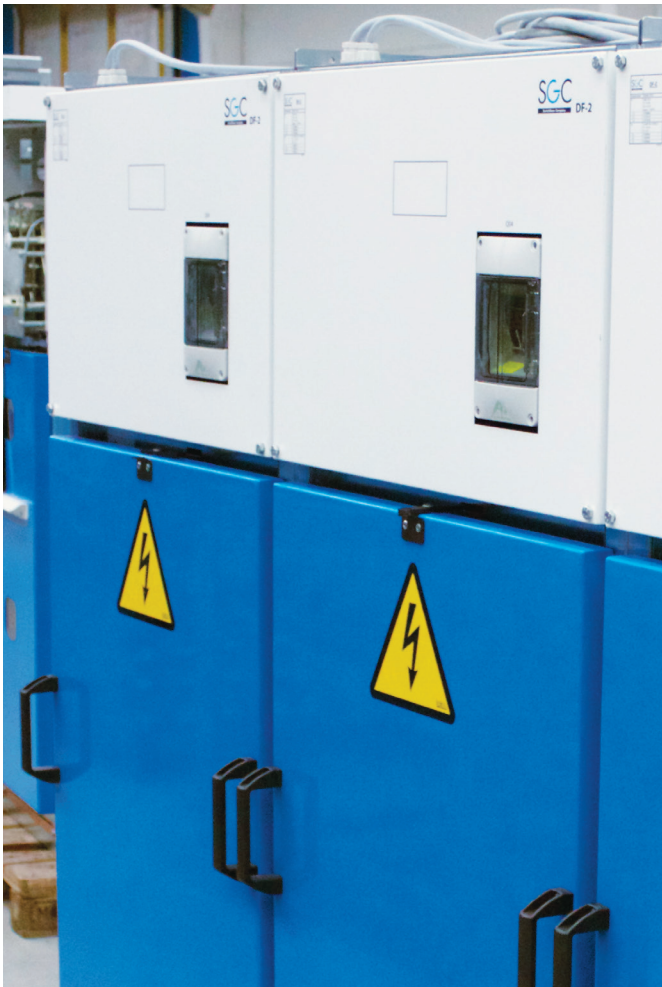

DF-C-500

Metering cubicle (SF₆ gas) type 1.

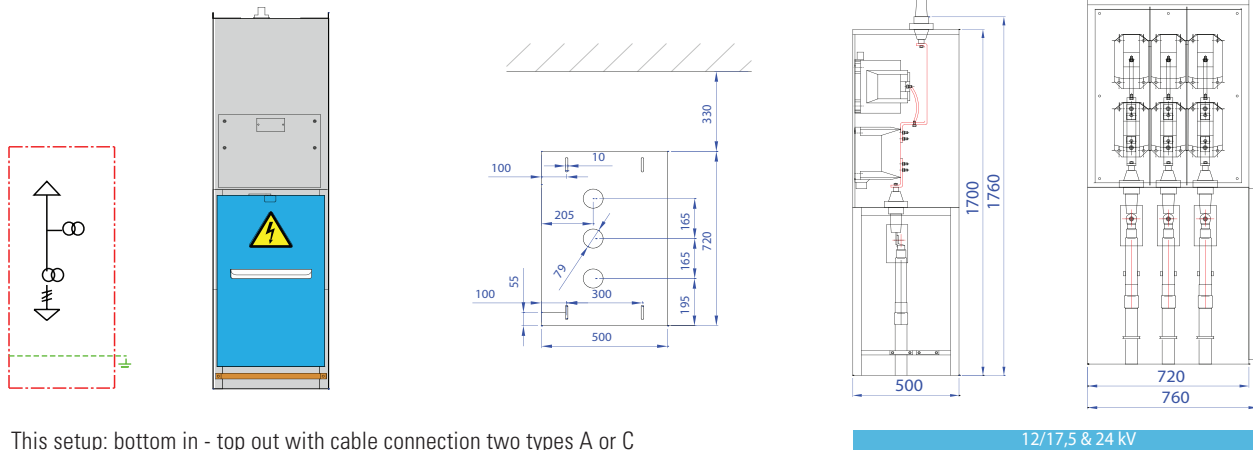

This setup: bottom in - top out with cable connection two types A or C

Standard Equipment

- 3 TI's xA => 5A
- 3 Tp's xV => 110V, V3
- Floor panels
- Low voltage compartment
- Insulators with capacitive device for VDS (Voltage Detection System)

Options

- Additional current transformers
- Additional voltage transformer with or without MV and LV protection
- Support for the positioning of measuring transformers
- Measuring system with 3 CTs and 3 VTs
- Measuring system with kWh metering and Kvarh metering (requirements to be specified by the customer)
- Current measurement system
- Voltage measurement system
- Cubicle base: 200 mm, 300 mm or 400 mm high (Other dimensions on demand)
- Low voltage compartment safety box to secure voltage

The following current transformer CT specifications will be specified by the customer:

Primary current, secondary current, capacity and precision class, insulation class, rated short time current

The following voltage transformer VT specifications will be specified by the customer:

Primary voltage, secondary voltage, capacity and precision class, insulation class

APPLICATION

The DF-C-500 cubicle has been designed for positioning current and voltage transformers to measure energy consumption.

SPECIFICATIONS & DIMENSIONS

Rated Voltage	kV	12	17,5	24
Rated current	A	up to 1250	up to 1250	up to 800
Short-term current	kA	25	25	20
Time of the short duration of current	s	1	1	1
Width	mm	500	500	500
Depth	mm	720	720	720
Height	mm	1700	1700	1700
Weight	kg	240	240	240

OTHER OPTIONS & DIMENSIONS?

Please consult us for options and dimensions other than those mentioned in this catalogue.

Metering cubicle (SF₆ gas) type 2.

260

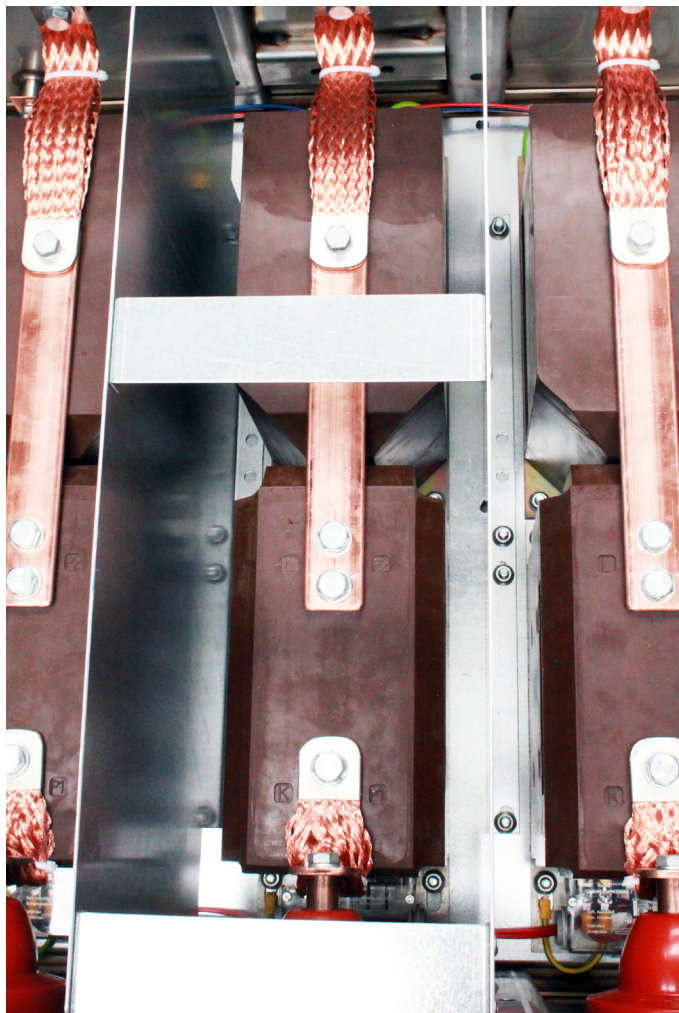
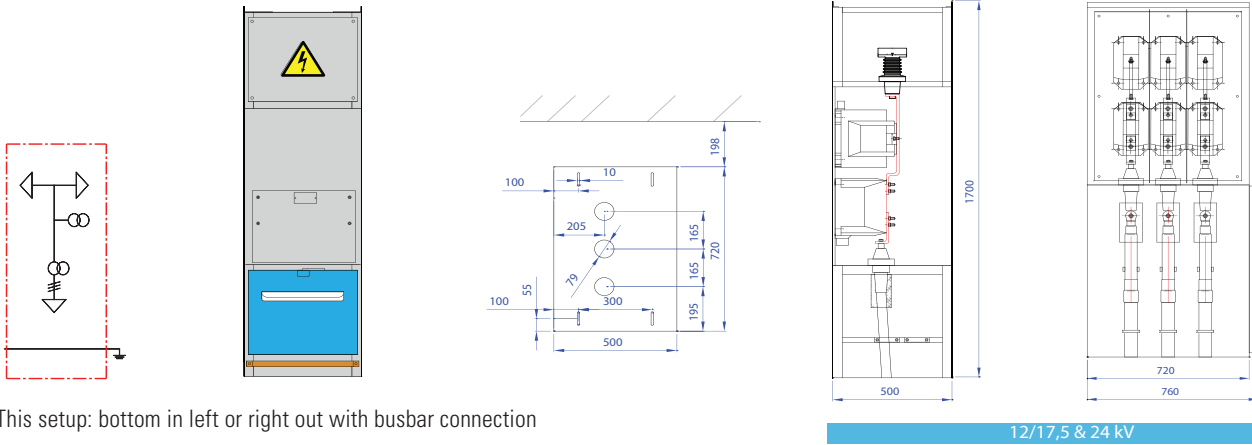

DF-LKB

Coupling cubicle.

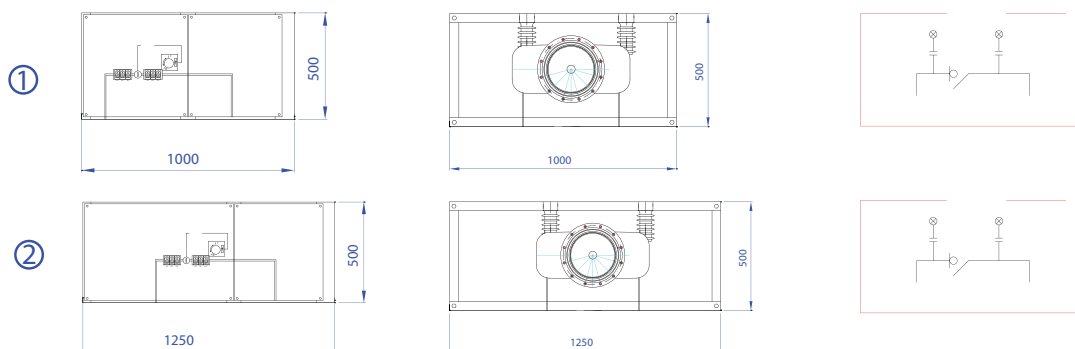

Standard Equipment

- 1 triple-phase load break switch RV44, class E3 according to IEC 62271-103, SF₆-insulation
- Low-voltage compartment
- Insulators with capacitive device for VDS (Voltage Detection System)
- Holder for capacitive voltage indicators load break switch left/right
- In case of coupling between two cubicles of 750 mm, a final piece of 250 mm will be provided

Options

- Set of auxiliary contacts on the load break switch
- Key interlock on load break switch
- Motor operation on load break switch: 24-48-110 V AC/DC & 220 V AC
- Earthing ball clamps on load break switch left/right
- Earthing ball clamps outside of cubicle
- Capacitive voltage indicators on load break switch left/right
- Button press control on load break switch
- Remote control on load break switch

APPLICATION

Coupling between cubicles with dimensions type 1 500-500mm (AA), 500-750mm (AD) and type 2 750-750mm (DD).

SPECIFICATIONS & DIMENSIONS

Rated Voltage	kV	12	17,5	24
Rated current	A	800/1250	800/1250	630/800
Short-term current	kA	25	25	20
Time of the short duration of current	s	1	1	1
Width	mm	1000/1250	1000/1250	1000/1250
Depth	mm	975	975	975
Height	mm	500	500	500
Weight	kg	162	176	176

OTHER OPTIONS & DIMENSIONS?

Please consult us for options and dimensions other than those mentioned in this catalogue.

DF-DKB

Coupling cubicle bridge between two rows of cubicles.

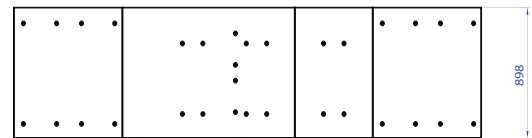
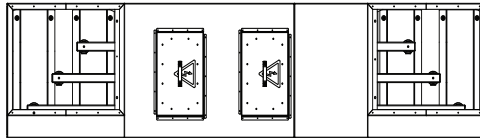
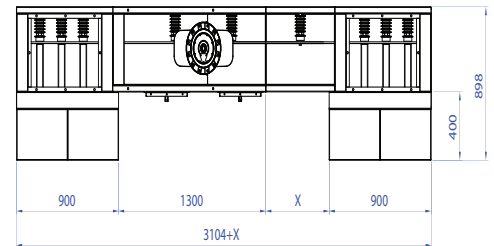
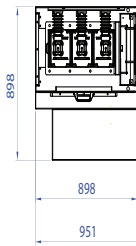
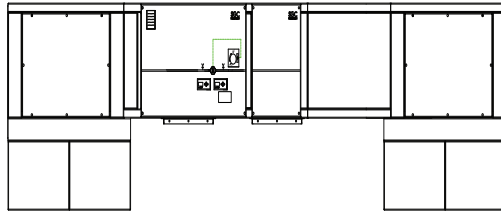
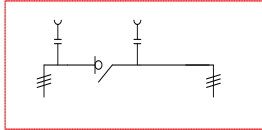

Standard Equipment

- 1 triple-phase load break switch RV44, class E3 according to IEC 62271-103, SF₆-insulation
- Low-voltage compartment
- Insulators with capacitive device for VDS (Voltage Detection System)
- Holder for capacitive voltage indicators load break switch left/right
- In case of coupling between two cubicles of 750 mm, a final piece of 250 mm will be provided

Options

- Set of auxiliary contacts on the load break switch
- Key interlock on load break switch
- Motor operation on load break switch: 24-48-110 V AC/DC & 220 V AC
- Earthing ball clamps on load break switch left/right
- Earthing ball clamps outside of cubicle
- Capacitive voltage indicators on load break switch left/right
- Button press control on load break switch
- Remote control on load break switch

APPLICATION

Coupling between two rows of cubicles. One part is made to measure (X).

SPECIFICATIONS & DIMENSIONS

Rated Voltage	kV	12	17,5	24
Rated current	A	800/1250	800/1250	630/800
Short-term current	kA	25	25	20
Time of the short duration of current	s	1	1	1
Width	mm	1000/1250	1000/1250	1000/1250
Depth	mm	975	975	975
Height	mm	500	500	500
Weight	kg	310	310	310

OTHER OPTIONS & DIMENSIONS?

Please consult us for options and dimensions other than those mentioned in this catalogue.

DF-K

Cable Cubicle.

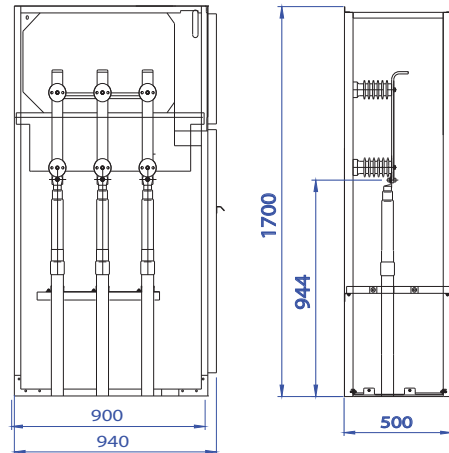
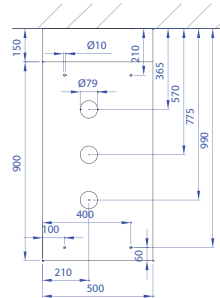
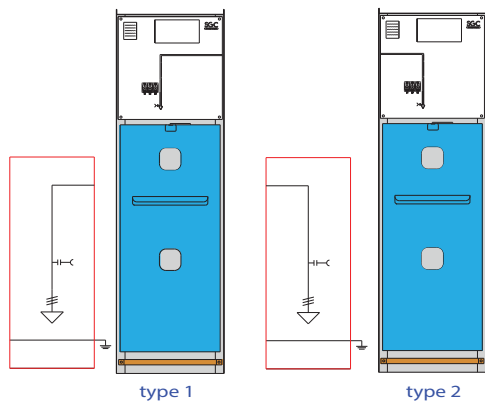

12/17,5 & 24 kV

Options

- Holder for capacitive voltage indicators
- Capacitive voltage indicators
- Short-circuit detectors (to be specified by the customer when ordering)
- Earthing switch (see type 3 & 4 p. 55)
- Set of auxiliary contacts on earthing switch
- Key interlock on earthing switch
- Earthing ball clamps
- Current transformers in the busbar
- Voltage transformers with or without protection in the busbar
- Cubicle base: 200 mm, 300 mm or 400 mm height (other dimensions on demand)
- Floor panels
- Door interlock
- arc-killer

APPLICATION

Cubicles of the DF-2 type equipped to bring in a supply cable. However, a DF-K cubicle can also contain a busbar and can be used as rising cubicle of the rail set.

Possible connections:

Type 1: Bottom in - top left out,
Type 2: Bottom in - top right out

SPECIFICATIONS & DIMENSIONS

Rated Voltage	kV	12	17,5	24
Rated current	A	800/1250	800/1250	800/1250
Short-term current	kA	25	25	20
Time of the short duration of current	s	1	1	1
Width	mm	M	M	M
Depth	mm	1050	1050	1050
Height	mm	M	M	M
Weight (*)	kg	55	55	55

OTHER OPTIONS & DIMENSIONS?

Please consult us for options and dimensions other than those mentioned in this catalogue.

DF-K + ESW

Cable Cubicle and earthing switch.

75

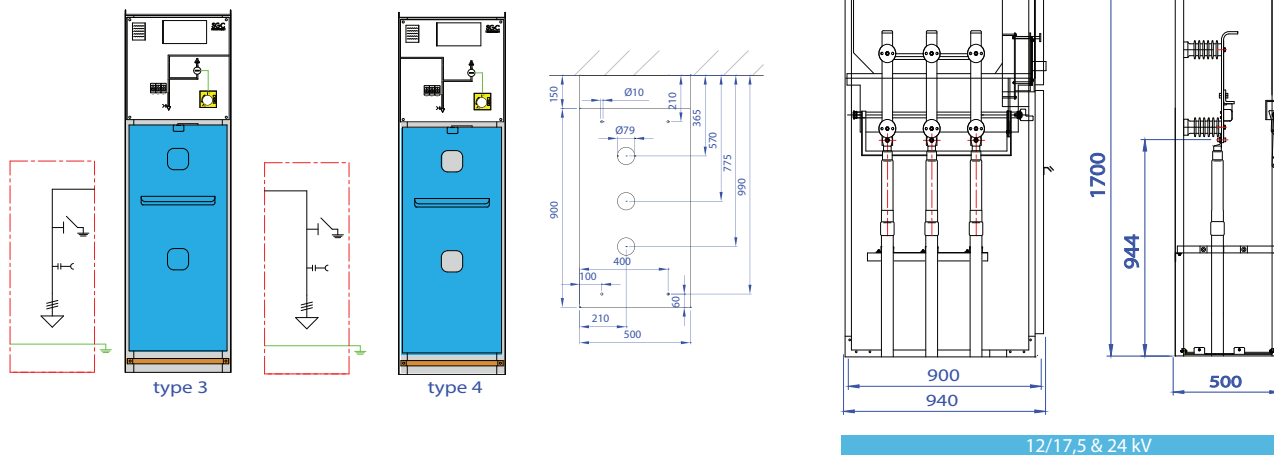

Options

- Holder for capacitive voltage indicators
- Capacitive voltage indicators
- Short-circuit detectors (to be specified by the customer when ordering)
- Set of auxiliary contacts on earthing switch
- Key interlock on earthing switch
- Earthing ball clamps
- Current transformers in the busbar
- Voltage transformers with or without protection in the busbar
- Cubicle base: 200 mm, 300 mm or 400 mm height (other dimensions on demand)
- Floor panels
- Door interlock
- arc-killer (see p. 56)

APPLICATION

Cubicles of the DF-2 type equipped to bring in a supply cable. However, a DF-K cubicle can also contain a busbar and can be used as rising cubicle of the rail set.

Possible connections:

Type 3: Bottom in - top left out
Type 4: Bottom in - top right out

SPECIFICATIONS & DIMENSIONS

Rated Voltage	kV	12	17,5	24
Rated current	A	800/1250	800/1250	800/1250
Short-term current	kA	25	25	20
Time of the short duration of current	s	1	1	1
Width	mm	M	M	M
Depth	mm	1050	1050	1050
Height	mm	M	M	M
Weight (*)	kg	55	55	55

OTHER OPTIONS & DIMENSIONS?

Please consult us for options and dimensions other than those mentioned in this catalogue.

DF-K+ + ESW

Cable Cubicle with Arc-Killer, gas exhaust duct and earthing switch.

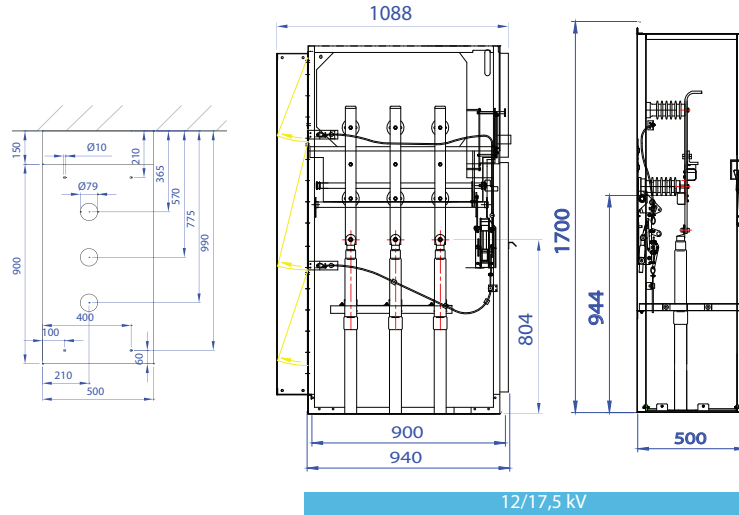
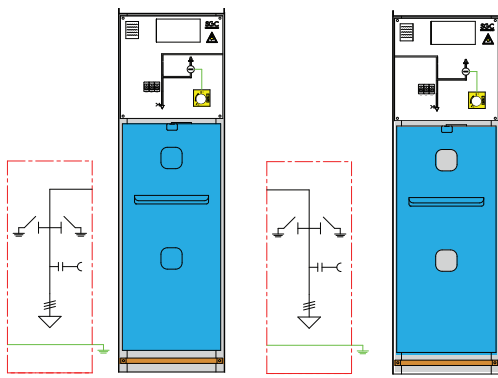

Options

- Holder for capacitive voltage indicators
- Capacitive voltage indicators
- Short-circuit detectors (to be specified by the customer when ordering)
- Set of auxiliary contacts on earthing switch
- Key interlock on earthing switch
- Earthing ball clamps
- Current transformers in the busbar
- Voltage transformers with or without protection in the busbar
- Cubicle base: 200 mm, 300 mm or 400 mm height (other dimensions on demand)
- Floor panels
- Door interlock

APPLICATION

Cubicles of the DF-2 type equipped to bring in a supply cable. However, a DF-K cubicle can also contain a busbar and can be used as rising cubicle of the rail set.

Possible connections:
Bottom in - top left out,
Bottom in - top right out

SPECIFICATIONS & DIMENSIONS

Rated Voltage	kV	12	17,5
Rated current	A	800/1250	800/1250
Short-term current	kA	25	25
Time of the short duration of current	s	1	1
Width	mm	750	750
Depth	mm	1050	1050
Height	mm	1700	1700
Weight	kg	95	95

OTHER OPTIONS & DIMENSIONS?

Please consult us for options and dimensions other than those mentioned in this catalogue.

4. INSTALLATION GUIDELINES

IN GENERAL

Because of the small dimensions of the different functional units, the DF-2 system is perfectly suited to cases where space is an important factor. From a practical point of view, it means that the space where the switchgear is positioned, has to meet IEC recommendations. By observing IEC recommendations, positioning the different cubicles can happen effortlessly. What's more, the final result will look flawless.

When the switchgear is positioned on the provided base, the outer dimensions of the cubicles will still need to be taken into account, to position it in a stable way. In order to resist an internal arc, each cubicle needs to be anchored with the provided bolts.



The following items are of great importance during the installation and demand strict observance:

4.1. TECHNICAL ROOM HEIGHT

An unobstructed height of at least 2200 mm is required. For dry transformers with a capacity of 1250 kVA or more, the unobstructed height of the room needs to be at least 2500 mm.

4.2. ACCESS DOORS DIMENSIONS

The minimal door height of the room should be 2200 mm. It is important to note that all passageways to the space need to have the same dimensions. If only a DF-A, DF-P, DF-C or DF-D has been installed, a door height of 2000 mm will be sufficient. In that case there are no transformers located in the room. The width of all access doors can be chosen depending on the selected cubicles: dimensions of the widest cubicle + 100 mm for a standard passageway. For the correct dimensions of all cubicles we refer to the modules overview in this catalogue starting on p.12.

If the room requires a transformer, its dimensions will have to be taken into account. The customer can always read about these dimensions on the installation plans provided by SGC - SwitchGear Company upon ordering.

If the room cannot be accessed directly from the outside, all access doors have to meet the previously mentioned dimensions. If the room is accessed by a corridor, one has to take the rotation into account: the cubicle and/or the transformer will need to be turned into the room.

4.3. MINIMUM FREE PASSAGE FOR THE CUBICLES

The minimum free passage for the cubicles has to be at least 1200 mm. However, a passage of 2500 mm is preferable because of the internal arc resistance. The free passage for the transformer cubicles (DF-T) starting from 1000 kVA, is 2000 mm. The cubicles need to be positioned at a distance of 150 mm from the wall because of the internal arc resistance. The transformer can be positioned against the wall.

4.4. EXAMPLE LAY-OUT OF MV ROOM



Other specifications are possible according to distributor guidelines.

4.5 TECHNICAL ROOM VENTILATION

It is important to ventilate the technical room sufficiently. Therefore the total losses of the transformer should be taken into account, and the average temperature of the room should not exceed 25°C.

4.6 POSITIONING IN TECHNICAL ROOMS OF LEVEL -1

If the installation is not placed on the ground floor, there must be an access hatch to the level in question. The minimum dimensions of this hatch must always be 400 mm greater than the dimensions of the largest cubicle of the transformer. For the cubicle dimensions we refer to the modules overview in this catalogue starting on p.12. The dimensions have also been clearly indicated on the drawings.

4.7. GENERAL REMARKS

The DF-2 cubicles are designed for indoor use and are therefore placed in a room reserved for this purpose. This room should have a normal ambient temperature (a maximum of 45°C) and a normal humidity level. The cubicles are suited for placement at elevated levels < 1000 m.

For exposures to different temperatures and levels please consult SGC - SwitchGear Company. If several transformers will be installed, special attention needs to be paid to ventilation.



IMPORTANT :

When positioning cubicles please consider :

- **perfect levelling of the floor**
- **the measurements of the access doors**

(If the room cannot be directly accessed from the outside, all access doors have to be able to accommodate the size.)

Thanks to the modular concept of the system, installation of the cubicles as well as connection can be achieved very easily. We advise you to follow the guidelines on the plans strictly and at all times. This will allow the installation to be carried out even more smoothly.

For more detailed installation prescriptions please see our DF-2 manual which is delivered with every cubicle.

5. PRODUCTION PROCESS

5.1. PRODUCTION PROCESS OF THE DF-2 CUBICLES AT LANDEGEM

The DF-2 system is the result of a combination of modern design technologies and economical, ergonomic and environmentally friendly production processes.

It all starts in the design department where your drawings will be **customized via CAD applications**. As soon as the drawings are approved, production can start. SGC - SwitchGear Company's steel plate department works with the most modern machinery, programmed by a CAD/CAM system.

The automated laser, punch and pleating section can **truly be considered unique**. Two ultra-fast punch-corner cutting scissor machines are each provided with an automatic loading and sorting system which sorts and saves the items.

The numerous possibilities of the matrixes and plate feeders ensure that the cubicles can be uniformly produced as 100% user-friendly.

After the laser and punch processing, several panels are pleated on the fully automatic pleating bank, sorted and possibly moved on to a CNC-operated welding robot. This machine welds the fitting bolts and corners of the door panels and other parts.

The doors are now subjected to a complete process where they are degreased, stained, phosphated, passivated and given an additional rinse with demineralised water.

They are automatically sprayed with polyester powder in a powder spray cabin, after which they are heated in an oven at 200°C.

The complete cubicle structure has been constructed out of high-quality galvanized plates, it is resistant to corrosion and **has a long life span**.



“DF-2: modern technology & ergonomic, eco-friendly production processes...”



In the assembly hall the specialized units are first pre-assembled. This division allows us to devote the necessary care to obtaining a perfect balance with, and a correct assembly of the various components. In the next stage the cubicles are assembled. This stage is subject to strict assembly procedures.

After assembly, all cubicles undergo an extremely thorough control. The electrical tests include resistance measurements on the RV44 load break switch and EM20 earthing switch. The cubicle is subjected to a voltage test of 50 kV / 1 min. The most striking test is the one where the closing speed of the load break switch and earthing switch is measured. One can even check the post-vibration of the electrical points during switching on a digital screen. The mechanical tests are used to check all fitting material, and to examine the correct positions of parts and interlocks.

Right before being dispatched the cubicles will undergo a final control; this is where custom, optional features will be installed and checked separately.

The cubicle is now ready for dispatch ... **to a happy and satisfied customer!**



“Our cubicles are resistant to corrosion and have a long life span...”

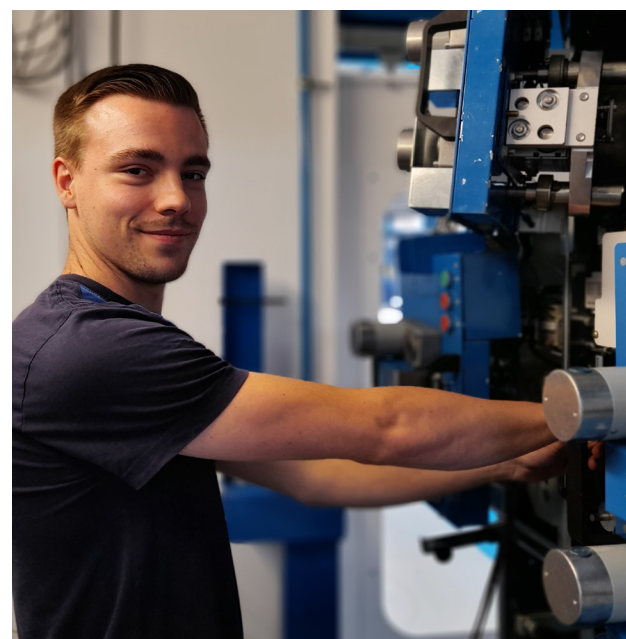

6. OTHER PRODUCTS BY SGC - SWITCHGEAR COMPANY

SGC offers solutions for all kinds of applications



**Get impressed.
Visit our
showroom virtually.**



Metal Enclosed

- Air insulated
- Always extendible
- Minimal amount of SF₆ (LBS)
- Switchgear is compartmentalized

Metal-Clad

Suitable for heavy industry and power stations

Ring Main Unit

- Gas insulated
- Compact monobloc
- Lateral extension optional

Other SF₆ free solutions

- Extendible blocs
- Switchgear is compartmentalized

INTERESTED IN OUR PRODUCTS,
PRODUCTION PROCESS OR PLANT?

Please contact our Sales Team. Send an e-mail to sales@switchgearcompany.eu for a guided tour, information on our products or visit our website www.switchgearcompany.eu



DF-2(+)

- Modular design
- Two position load break switch
- LSC 2A
- Ur:12-24kV; Ir: 630-1250A



DF-3(+)

- Compact modular design
- Three position load break switch
- LSC 2A
- Ur:12-24kV; Ir: 630A



DW-2

- AIS - SF₆ Free
- Withdrawable circuit breaker with metallic shutters
- 4 separate compartments
- LSC 2B
- Ur:12-17.5kV; Ir: 630-2000A



GI-2

- Gas insulated switchgear
- Modular
- Ur: 12/17,5/24 kV
- Ir: 630-1250-1600-2500 A



DR-6(+)/DT-6(+)

- Monobloc with cable feeder and/or switch fuse combination
- Extension with monobloc and/or individual units
- Three position load break switch
- LSC 2A
- Ur:12-24kV; Ir: 630A



DI-2

- Monobloc with cable feeder and/or switch fuse combination
- Extension with individual units
- Two position load break switch
- LSC 2A
- Ur:36kV; Ir: 400-630A

IS



SI-2

- Modular
- Two position load break switch
- IP 68
- LSC 2A
- Ur:12-15kV; Ir: 630A



N₂ Blue

- Insulation medium: Nitrogen
- Flexible modular system
- Ur: 17,5 kV; Ir: 2500 A

N₂ Blue
NITROGEN
SF₆ FREE



“ *Our vision is to be a global player and to be the premier switchgear company in every market that we serve. Being premier does mean being the best in terms of operator safety, quality, durability, innovation, technology, delivery and profitability, resulting in long term customer satisfaction.* ”



SGC - SwitchGear Company nv

Medium voltage switchgear, built to last.

SGC - SwitchGear Company nv has been supplying reliable products for electrical distribution for more than 40 years. Innovative ideas and environmental care are the driving forces behind SGC - SwitchGear Company. The development of complete solutions consists of a minimum number of components, all of which have an exceptional life span. SGC - SwitchGear Company nv stands for exceptional quality and superior customer care. Your desired specifications and deadlines are our main concern.

An exclusive factory and highly automated production lines are key factors in our “state of the art” components and systems. It enables us to develop the DF-2, DF-3, DR-6/DT-6 , DI-2, SI-2, AF-6, DW-2, GI-2 and N₂ Blue to the highest quality standards. When it comes to delivery times, prices and products SGC - SwitchGear Company nv delivers.





SGC - SwitchGear Company nv

Moorstraat 24
9850 Landegem
Belgium

+32 (0)9/321.91.12

www.switchgearcompany.eu

info@switchgearcompany.eu

Follow SGC on :   

Get impressed.

**Visit our
showroom virtually.**



THE SPECIALIST IN MEDIUM VOLTAGE SWITCHGEAR